

rotork[®]
Instruments

Air Preparation

Regulators, Pressure Regulators, Lubricators and Accessories



MIDLAND-ACS
A rotork[®] Brand

Keeping the World Flowing

Contents

rotork® Midland

Section	Page	Section	Page
Introduction	3	3575 Series air service units	
3525 Series air service units		Filter Regulators	31
Compact Filter Regulator	4	Filters	33
3550 Series air service units		Pressure Regulators	35
Filter Regulators	6	Over Pressure Device	
Filters	10	Features and Benefits	37
Pressure Regulators	13	General Description	38
Accessories	15	Development	38
3500 Series air service units		Performance Characteristics	39
Filter Regulators	17	Rotork Midland in the Oil and Gas Industries	41
Filters	20	Rotork Instruments	41
Pressure Regulators	24	Rotork Site Services – Service and Support	42
Lubricator	26		
Accessories	28		



Rotork is the global market leader in valve automation and flow control. Our products and services are helping organisations around the world to improve efficiency, assure safety and protect the environment.

We strive always for technical excellence, innovation and the highest quality standards in everything we do. As a result, our people and products remain at the forefront of flow control technology.

Uncompromising reliability is a feature of our entire product range, from our flagship electric actuator range through to our pneumatic, hydraulic and electro-hydraulic actuators, as well as instruments, gearboxes and valve accessories.

Rotork is committed to providing first class support to each client throughout the whole life of their plant, from initial site surveys to installation, maintenance, audits and repair. From our network of national and international offices, our engineers work around the clock to maintain our position of trust.

Rotork. Keeping the world flowing.

Introduction

As a specialist manufacturer of stainless steel large flow air service equipment we offer comprehensive, purpose designed, engineered and manufactured solutions for filtration and regulation of compressed air and gases for the actuation industries.



Certification Options Available



3525 Series air service units – 1/4" Compact Filter Regulator

A 316L stainless steel combined unit for filtration and regulation of compressed air and gases.

Features and Benefits

- Designed for severe environments
- Self relieving
- 1/4" NPT ported filter regulator
- 550 l/min (9.17 dm³/s) flow capacity at 1 bar differential
- 0.5 - 8 bar outlet pressure range
- 20 bar maximum inlet pressure
- Full 316L stainless steel construction
- FKM Seals
- Manual drain
- 25 µm filter
- Mounting bracket included as standard



Ambient Temperature Range

- -20 to +80 °C (-4 to +176 °F)

Port & Connections

- Port: 1/4" NPT
- Gauge/breather: 1/8" NPT
1/4" NPT optional, add suffix 'X' (refer to table)

Filter

- 25 µm nominal
- Condensate bowl capacity: 5 cc

Flow

At 10 bar (145 psi) supply pressure, 6.3 bar (91.35 psi) secondary pressure, 1 bar (14.5 psi) pressure drop

- 550 l/min (19.42 SCFM)

Operating Media

- Instrument air, sweet natural gas, inert gases

Accessories Available

- Stud mounting kit
- 0-11 bar pressure gauge

See page 5 for ordering details.

Flow Characteristics
(in accordance with BS6953 parts 1 & 2)

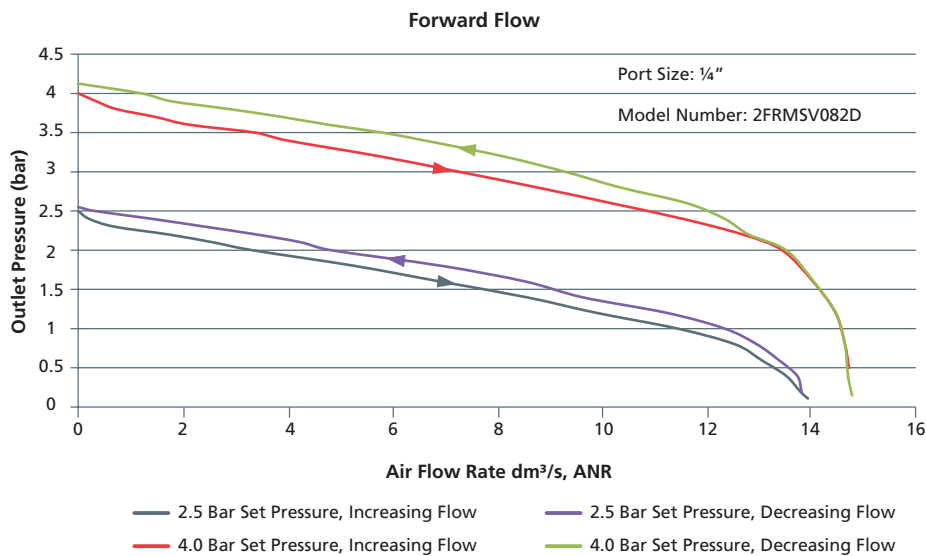

3525 Series air service units – 1/4" Compact Filter Regulator - Engineering Drawings

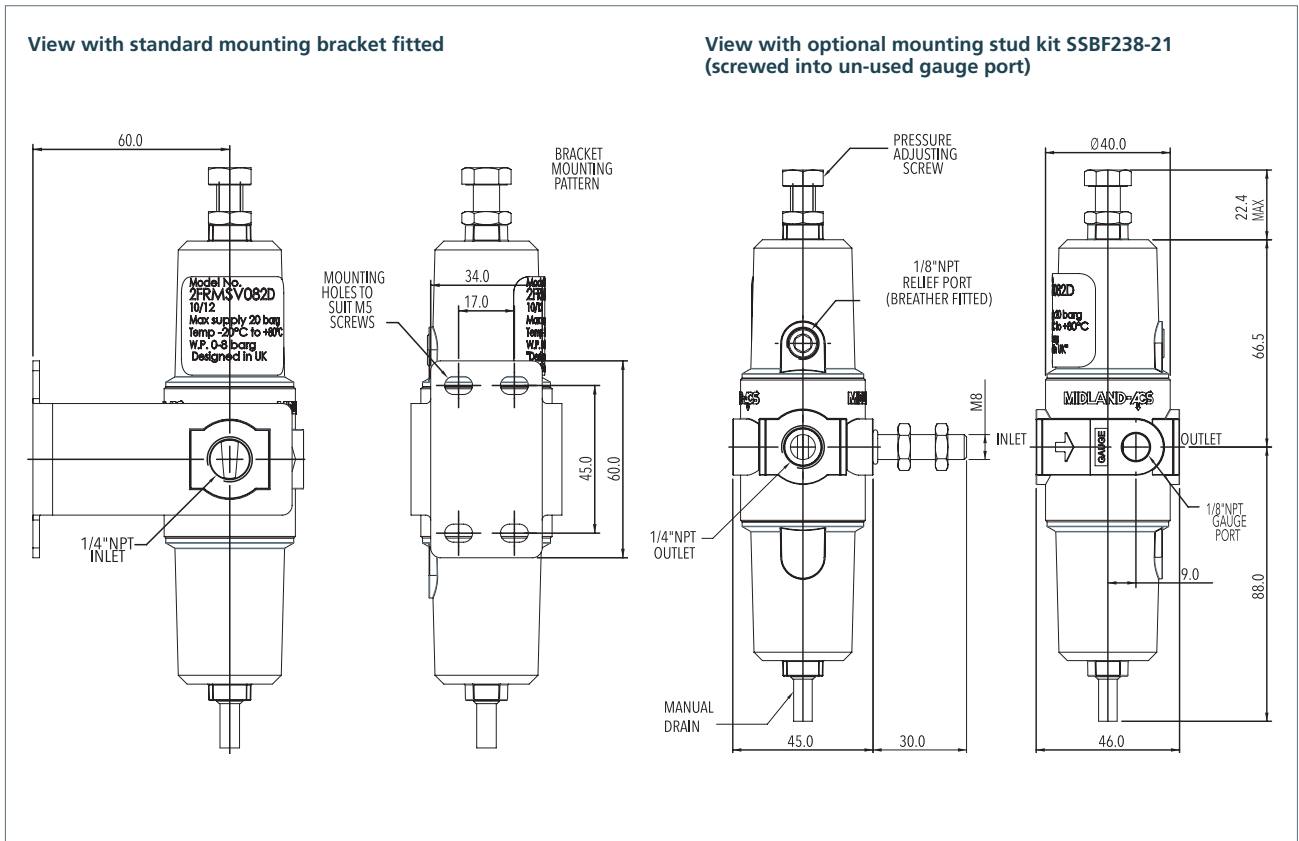

Ordering Information

Product Code	Size	Gauge Port Size	Regulated Pressure bar (psi)	Max Inlet Pressure bar	Weight kg	CV
2FRMSV082D	1/4" NPT	1/8" NPT	0.5 to 8.0 (7.2 to 116)	20	0.675	0.48
2FRMSV082DX	1/4" NPT	1/4" NPT (Gauge Port Option)	0.5 to 8.0 (7.2 to 116)	20	0.675	0.48

Note:

Where 1/4" NPT gauge ports are required a 1/8" NPT to 1/4" NPT fitting will be provided. Price on application.

Accessories Ordering Information

Product Code	Item
SSBF238/21	Stud Mounting Kit
SSF153N/11 GLY	0-11 bar pressure gauge

Note:

Specification and engineering drawings for accessories available on request.

rotork[®]
Midland

3550 Series air service units – 1/4" to 3/4" Filter Regulator

A 316L stainless steel combined unit for filtration and regulation of compressed air and gases for the actuation industries.

Features and Benefits

- Specifically designed for severe environments
- Non or self-relieving
- 40 micron element stainless steel 316 as standard, 5 micron option available
- Ambient temperature range -20 to +80 °C (-4 to +176 °F) Low temperature option available
- 316L stainless steel construction
- Regulated pressure range from 0.50 to 12.0 bar depending on model selection
- Large flow characteristics
- NACE capability option available, standard temperature and manual drain only (consult factory)

Ambient Temperature Range

- Standard: -20 to +80 °C (-4 to +176 °F)¹
- Low temp: -50 to +80 °C (-58 to +176 °F)² optional

¹ When product is ordered as 'ATEX' ambient temperature range is -10 °C to +40 °C (14 °F to +104 °F) (T6) (EC Directive 94/9/EC).

² When product is ordered as 'ATEX' ambient temperature range is -50 °C to +40 °C (-58 °F to +104 °F) (T6) (EC Directive 94/9/EC).

Maximum Relief Flow

- At 2 bar (29 psi) secondary pressure
0.5 cc/sec (0.03 cu in/sec)

Flow

At 10 bar (145 psi) supply pressure, 6 bar (87 psi) secondary pressure, 1 bar (14.5 psi) pressure drop.

- 1/4" - 3,720 l/min (130 SCFM)
- 1/2" and 3/4" - 6,000 l/min (212 SCFM)

Maximum Inlet Pressure

- Manual drain - 20 bar (290 psi)
- Automatic drain - 17 bar (247 psi)

Ports NPT

(BSP option available - consult factory for part codes)

- 1/4", 1/2", 3/4"

Certification Options Available



Gauge Ports

- 1/8" NPT
- 1/4" NPT (option available - suffix product code with 'X')

Relief Vent Port

- 1/8" NPT (fitted with breather)
Note: Not fitted on low temperature option

Bowl Capacity

- 21 cc (1.28 cu ins)

Accessories Available

- Mounting brackets
- Stainless steel pressure gauge
- Hand wheel

See page 15-16 for ordering details

Operating Media

- Gases - air, inert gas, sweet (natural) and sour gases - NACE option available (consult factory)

Construction Materials

- Body/bonnet/bowl: 316L stainless steel
- Internals : 316L stainless steel and Ryton R-4
Note: on auto-drain version float is nylon, polyoxymethylene and rubber.
- Element: 40 micron 316 stainless steel (5 micron option available - suffix product code with '05')
- Seals: Standard option - Fluoroelastomer
Low temperature option - EPDM

3550 Series air service units – 1/4" to 3/4" Filter Regulator - Flow Characteristics

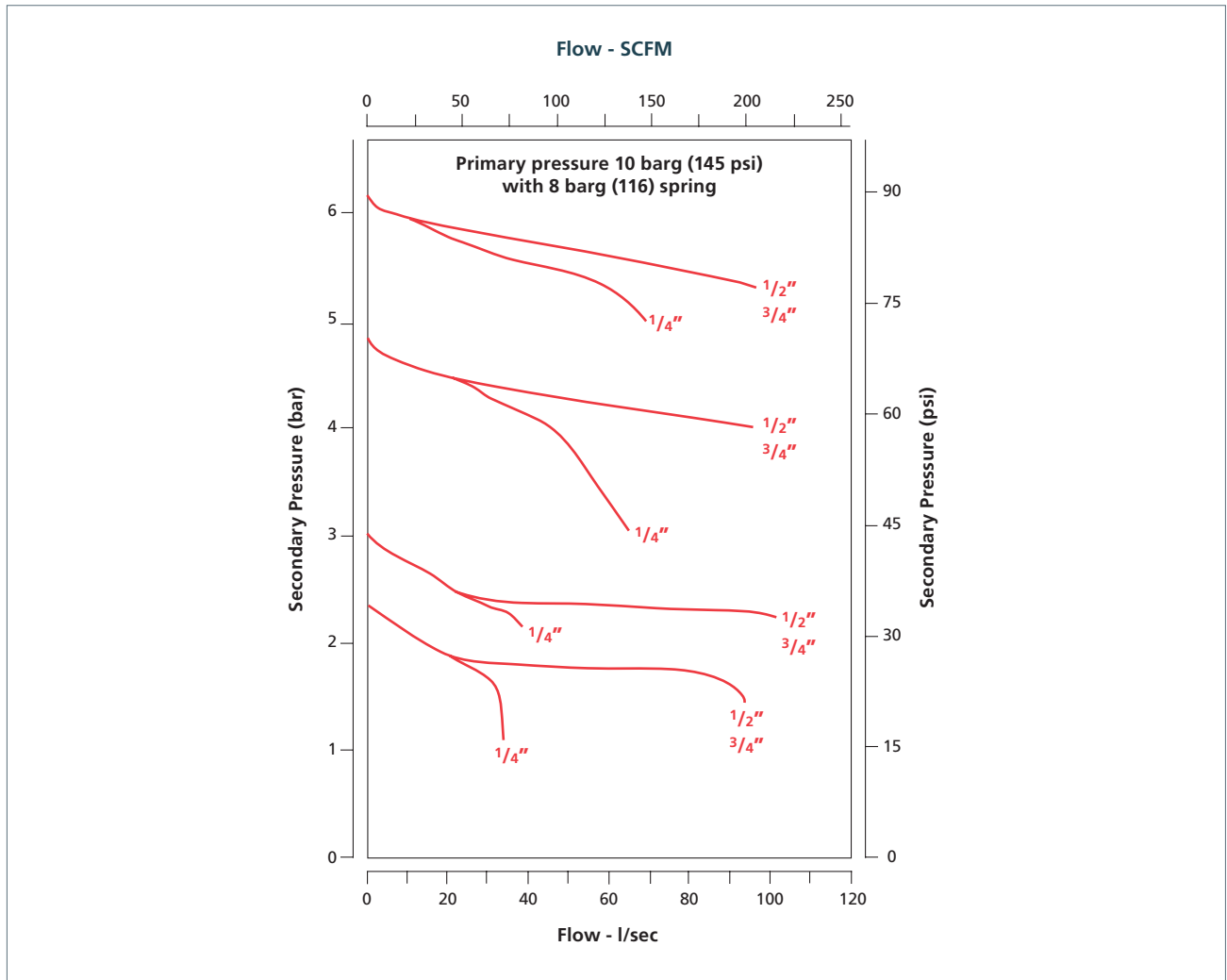

rotork®
Midland

3550 Series air service units – 1/4" to 3/4" Filter Regulators - Engineering drawings (manual drain)

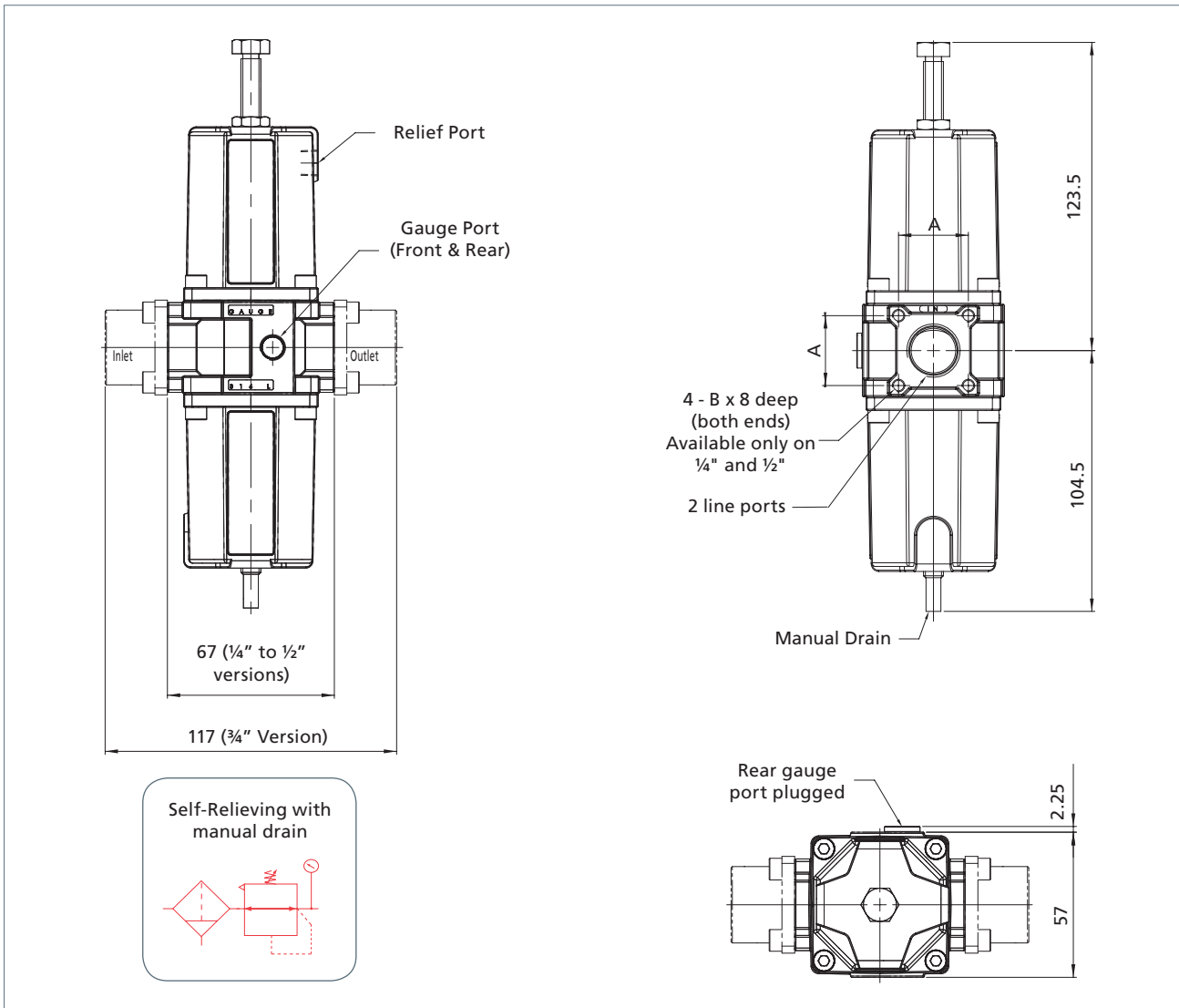

Standard Product Code	Low Temperature Version	Size	Filter	Regulated Pressure bar (psi)	Max Inlet Pressure bar	A	B	Weight kg	Cv
2FRMSV022A	2FRMSF022A	1/4"	Manual Drain	0.50 to 2.0 (7.2 to 29)	20	24	M4	1.75	2.4
4FRMSV022A	4FRMSF022A	1/2"				28	M5	1.75	4.4
6FRMSV022A	6FRMSF022A	3/4"				-	-	1.95	5.0
2FRMSV042A	2FRMSF042A	1/4"	Manual Drain	0.50 to 4.0 (7.2 to 58)	20	24	M4	1.75	2.4
4FRMSV042A	4FRMSF042A	1/2"				28	M5	1.75	4.4
6FRMSV042A	6FRMSF042A	3/4"				-	-	1.95	5.0
2FRMSV082A	2FRMSF082A	1/4"	Manual Drain	0.50 to 8.0 (7.2 to 116)	20	24	M4	1.75	2.4
4FRMSV082A	4FRMSF082A	1/2"				28	M5	1.75	4.4
6FRMSV082A	6FRMSF082A	3/4"				-	-	1.95	5.0
2FRMSV122A	2FRMSF122A	1/4"	Manual Drain	0.50 to 12.0 (7.2 to 174)	20	24	M4	1.75	2.4
4FRMSV122A	4FRMSF122A	1/2"				28	M5	1.75	4.4
6FRMSV122A	6FRMSF122A	3/4"				-	-	1.95	5.0

5 micron option available - suffix product code with '05'. 1/4" NPT gauge port option available - suffix product code with 'X'
 If ATEX certification is required suffix product code with 'ATEX'

3550 Series air service units — 1/4" to 3/4" Filter Regulators - Engineering Drawings (auto drain)

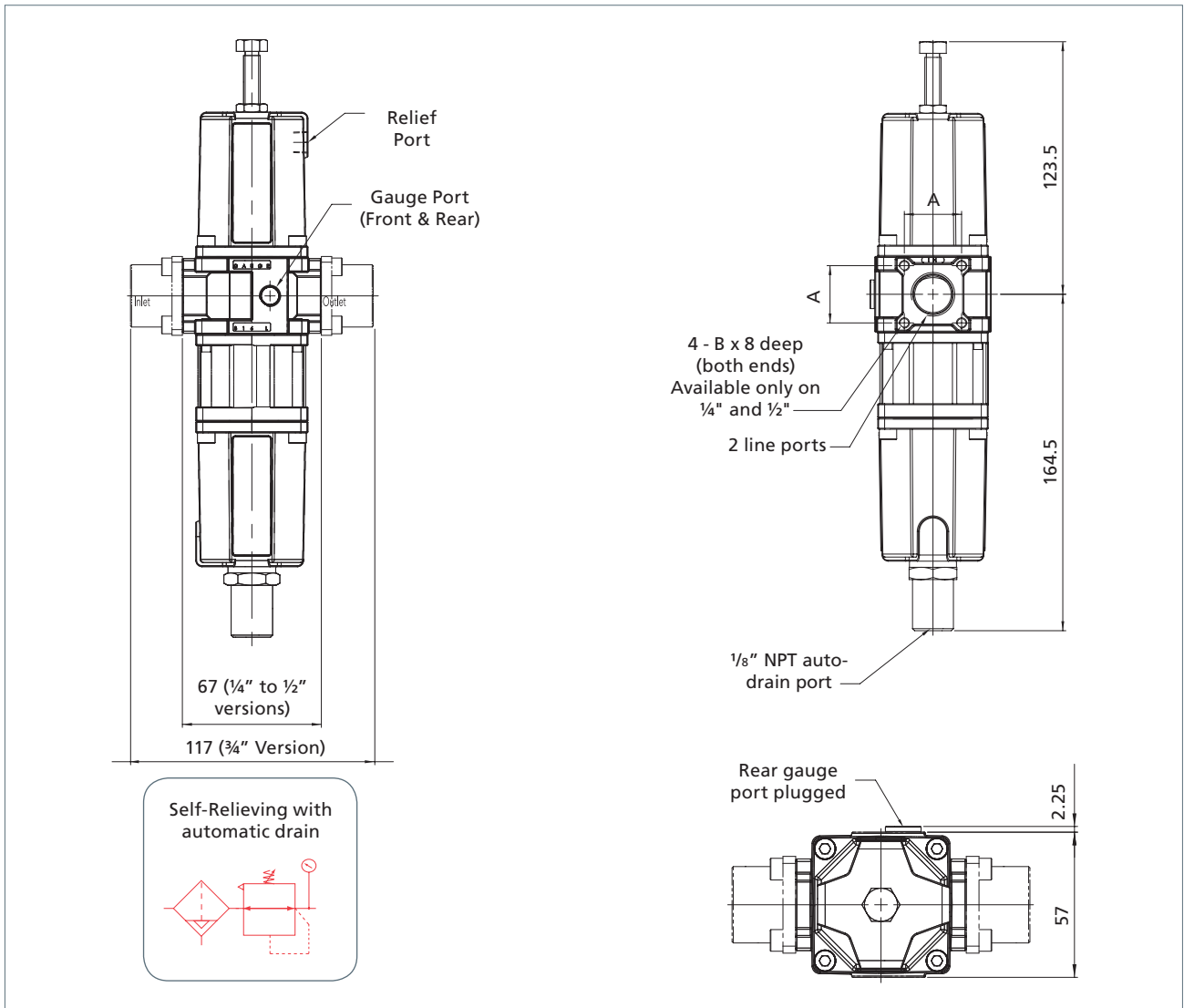

Product Code	Size	Filter	Regulated Pressure bar (psi)	Max Inlet Pressure bar	A	B	Weight kg	Cv
2FRASV022A	1/4"	Auto Drain	0.50 to 2.0 (7.2 to 29)	17	24	M4	2.05	2.4
4FRASV022A	1/2"				28	M5	2.05	4.4
6FRASV022A	3/4"				-	-	2.25	5.0
2FRASV042A	1/4"	Auto Drain	0.50 to 4.0 (7.2 to 58)	17	24	M4	2.05	2.4
4FRASV042A	1/2"				28	M5	2.05	4.4
6FRASV042A	3/4"				-	-	2.25	5.0
2FRASV082A	1/4"	Auto Drain	0.50 to 8.0 (7.2 to 116)	17	24	M4	2.05	2.4
4FRASV082A	1/2"				28	M5	2.05	4.4
6FRASV082A	3/4"				-	-	2.25	5.0
2FRASV122A	1/4"	Auto Drain	0.50 to 12.0 (7.2 to 174)	17	24	M4	2.05	2.4
4FRASV122A	1/2"				28	M5	2.05	4.4
6FRASV122A	3/4"				-	-	2.25	5.0

Low temperature version not available in auto drain.

5 micron option available - suffix product code with '05'. 1/4" NPT gauge port option available - suffix product code with 'X'

If ATEX certification is required suffix product code with 'ATEX'

3550 Series air service units – 1/4" to 3/4" Filters

A 316L stainless steel unit for filtration of compressed air and gases for the actuation industries.

Features and Benefits

- Specifically designed for severe environments
- 40 micron element stainless steel 316 as standard, 5 micron option available
- Ambient temperature range -20 to +80 °C (-4 to +176 °F) Low temperature version available
- 316L stainless steel construction
- Large flow characteristics
- NACE capability option available, standard temperature and manual drain only (consult factory)

Ambient Temperature Range

- Standard: -20 to +80 °C (-4 to +176 °F)¹
 - Low temp: -50 to +80 °C (-58 to +176 °F)² optional
- ¹ When product is ordered as 'ATEX' ambient temperature range is -10 °C to +40 °C (14 °F to +104 °F) (T6) (EC Directive 94/9/EC).
- ² When product is ordered as 'ATEX' ambient temperature range is -50 °C to +40 °C (-58 °F to +104 °F) (T6) (EC Directive 94/9/EC).

Maximum Inlet Pressure

- Manual drain - 20 bar (290 psi)
- Automatic drain - 17 bar (247 psi)

Flow

At 7 bar (102 psi) supply pressure, 0.35 bar (5 psi) pressure drop.

- 1/4" - 1,380 l/min (49 SCFM)
- 1/2" and 3/4" - 2,940 l/min (104 SCFM)

Ports NPT

(BSP option available - consult factory for part codes)

- 1/4", 1/2", 3/4"

Automatic Drain Port

- 1/8" NPT

Bowl Capacity

- 21 cc (1.28 cu ins)

Certification Options Available



Accessories Available

- Mounting brackets

See page 15 for ordering details

Operating Media

- Gases - air, inert gas, sweet (natural) and sour gases - NACE option available (consult factory)

Construction Materials

- Body/bonnet/bowl and internals: 316L stainless steel
Note: on auto-drain version float is nylon, polyoxymethylene and rubber.
- Element: 40 micron 316 stainless steel (5 micron option available - suffix product code with '05')
- Seals: Standard option - Fluoroelastomer
Low temperature option - EPDM

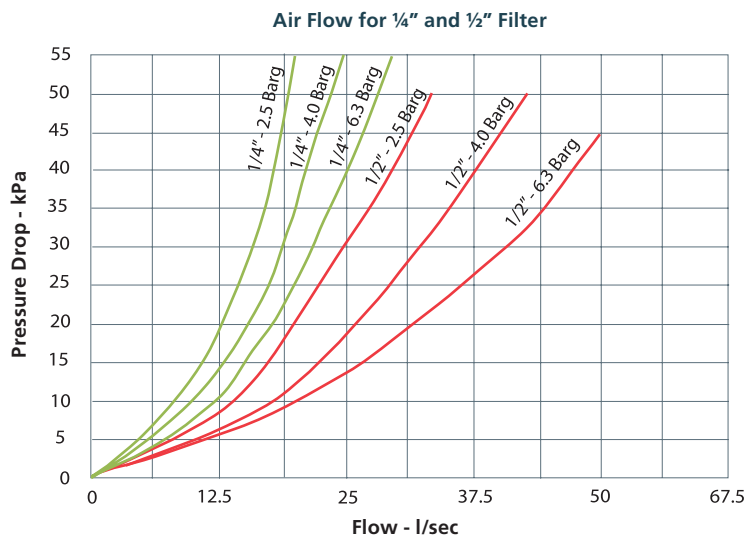

3550 Series air service units – 1/4" to 3/4" Filters - Engineering Drawings (manual drain)

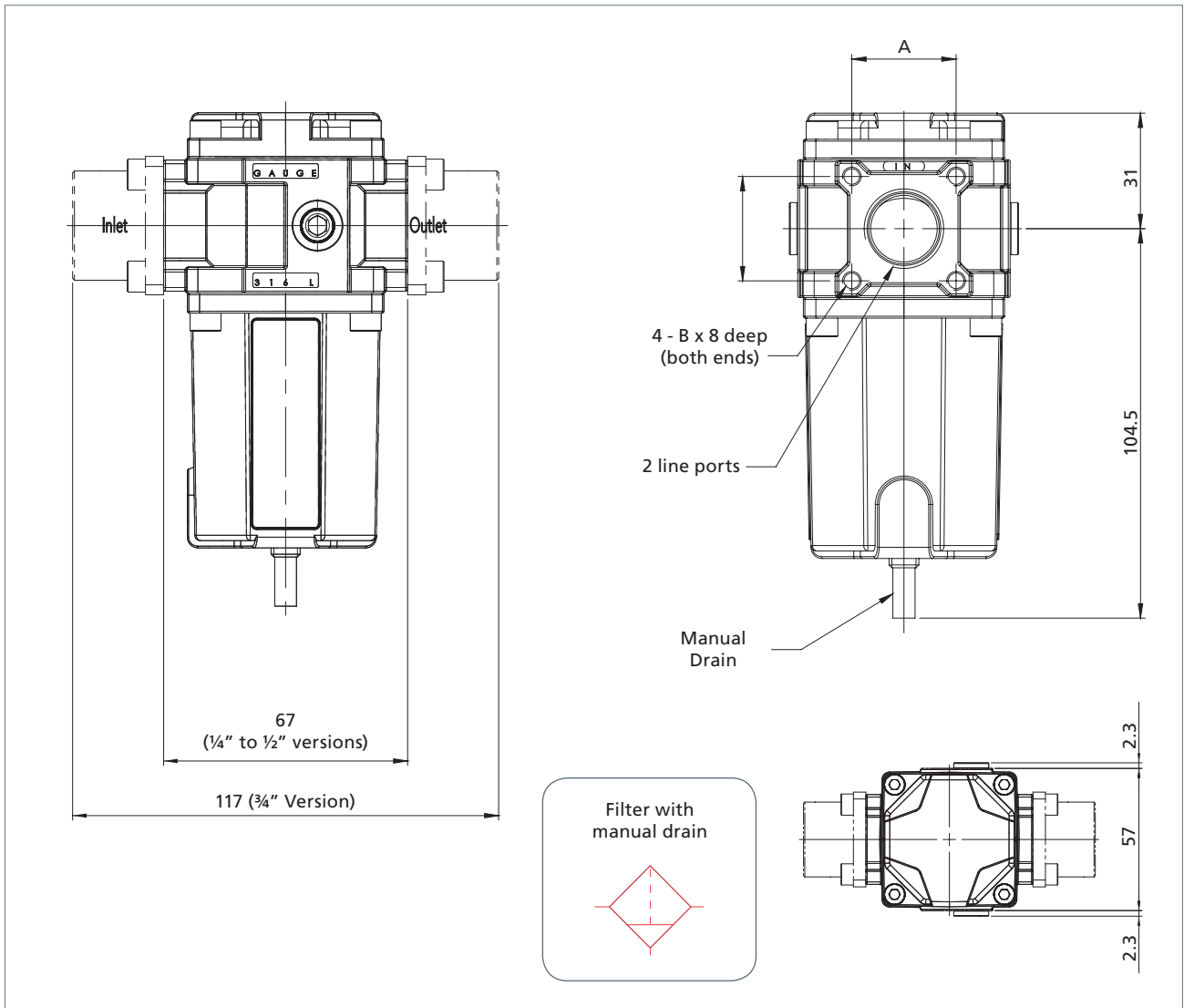

Product Code	Low Temperature Version	Size	Filter	Max Inlet Pressure bar	A	B	Weight kg	Cv
2FLMSV202A	2FLMSF202A	1/4"	Manual Drain	20	24	M4	1.3	2.4
4FLMSV202A	4FLMSF202A	1/2"			28	M5	1.3	4.4
6FLMSV202A	6FLMSF202A	3/4"			-	-	1.5	5.0

5 micron option available - suffix product code with '05'.
If ATEX certification is required suffix product code with 'ATEX'

rotork[®]
Midland

3550 Series air service units – 1/4" to 3/4" Filters - Engineering Drawings (auto drain)

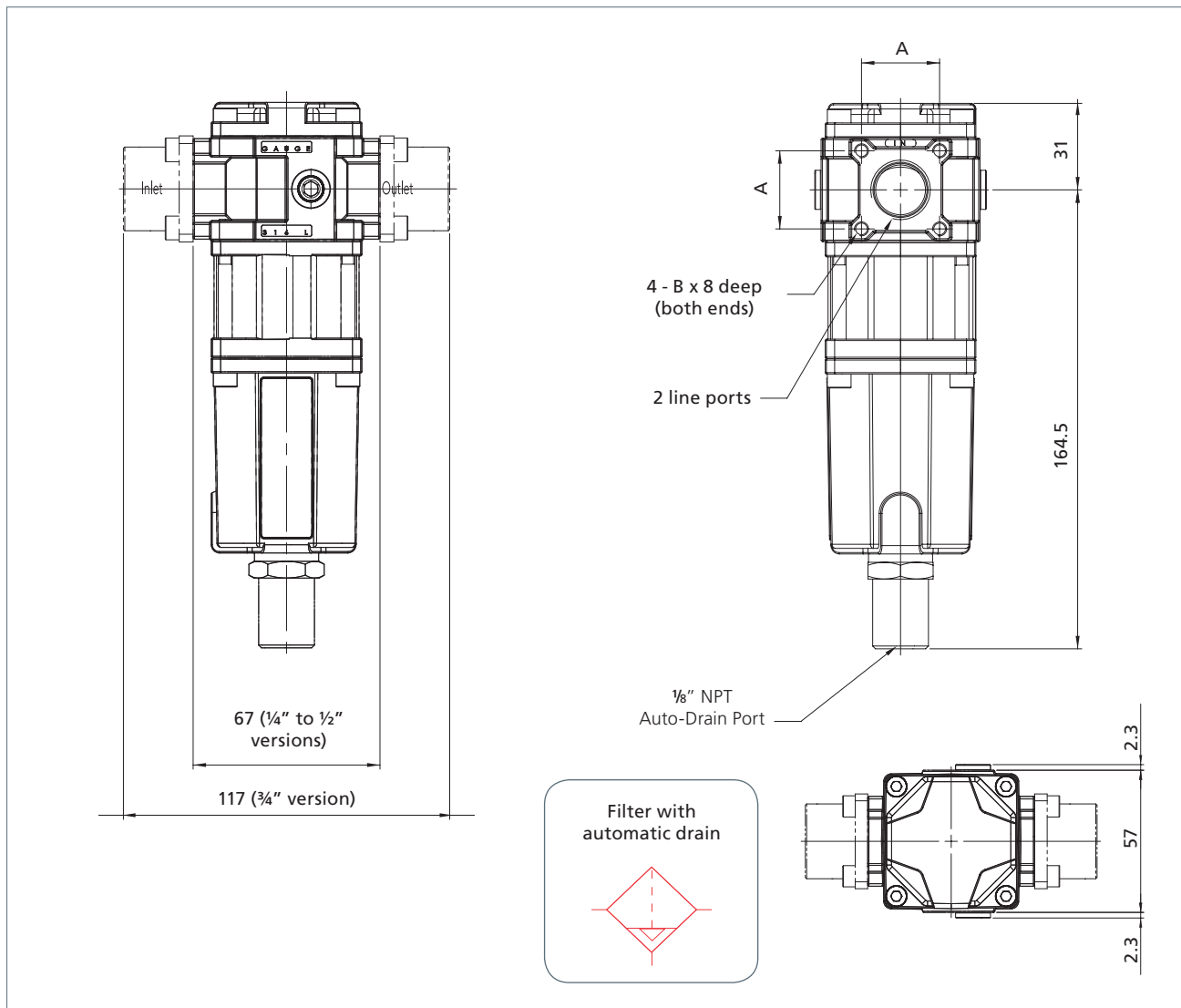

Product Code	Size	Filter	Max Inlet Pressure bar	A	B	Weight kg	Cv
2FLASV172A	1/4"	Auto Drain	17	24	M4	1.6	2.4
4FLASV172A	1/2"			28	M5	1.6	4.4
6FLASV172A	3/4"			-	-	1.8	5.0

Low temperature version not available in auto drain.
 5 micron option available - suffix product code with '05'.
 If ATEX certification is required suffix product code with 'ATEX'

3550 Series air service units – 1/4" to 3/4" Pressure Regulators

A 316L stainless steel unit for the pressure regulation of compressed air and gases for the actuation industries.

Features and Benefits

- Specifically designed for severe environments
- Non or self-relieving
- Ambient temperature range -20 to +80 °C (-4 to +176 °F)
Low temperature version available
- 316L stainless steel construction
- Large flow characteristics
- NACE capability option available, standard temperature only (consult factory)

Ambient Temperature Range

- Standard: -20 to +80 °C (-4 to +176 °F)¹
- Low temp: -50 to +80 °C (-58 to +176 °F)² optional

¹ When product is ordered as 'ATEX' ambient temperature range is -10 °C to +40 °C (14 °F to +104 °F) (T6) (EC Directive 94/9/EC).

² When product is ordered as 'ATEX' ambient temperature range is -50 °C to +40 °C (-58 °F to +104 °F) (T6) (EC Directive 94/9/EC).

Maximum Relief Flow

- At 2 bar (29 psi) secondary pressure
0.5 cc/sec (0.03 cu in/sec)

Flow

At 10 bar (145 psi) inlet pressure, 6 bar (87 psi) secondary pressure with 1 bar (14.5 psi) pressure drop.

- 1/4" - 3,780 l/min (133 SCFM)
- 1/2" and 3/4" - 6,180 l/min (218 SCFM)

Ports NPT

(BSP option available - consult factory for part codes)

- 1/4", 1/2", 3/4"

Gauge Ports

- 1/8" NPT
- 1/4" NPT (option available - suffix product code with 'X')

Relief Vent Port

- 1/8" NPT (fitted with breather)
Note: Not fitted on low temperature option

Certification Options Available



Accessories Available

- Mounting brackets
- Stainless steel pressure gauge
- Hand wheel

See page 15-16 for ordering details

Operating Media

- Gases - air, inert gas, sweet (natural) and sour gases - NACE option available (consult factory)

Construction Materials

- Body/bonnet/bowl and internals: 316L stainless steel
- Seals: Standard option - Fluoroelastomer
Low temperature option - EPDM

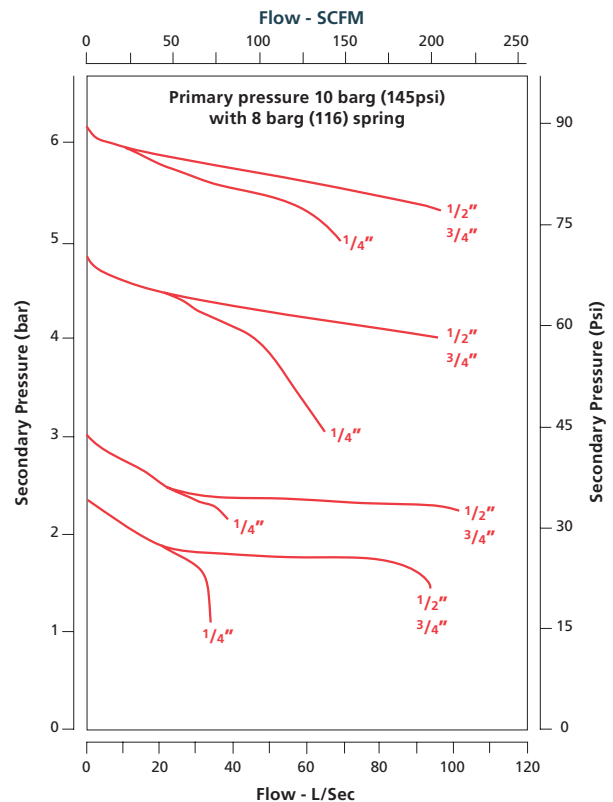

3550 Series air service units – 1/4" to 3/4" Pressure Regulators - Engineering Drawings

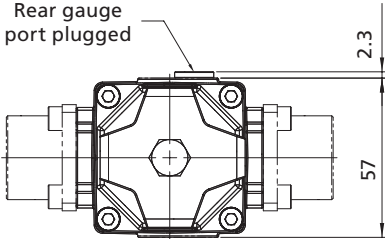
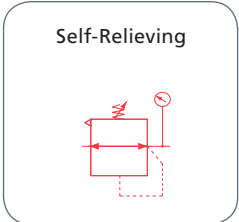
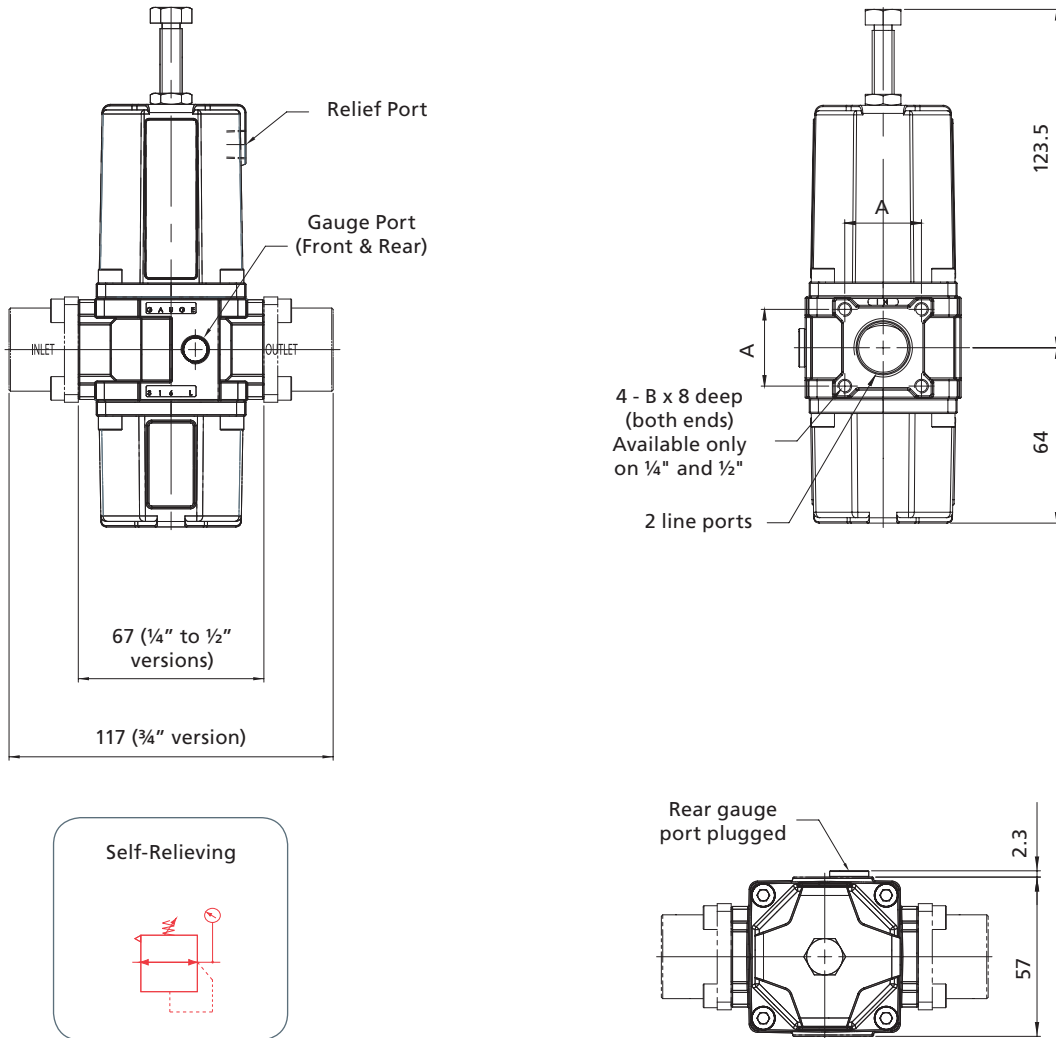

Product Code	Low Temperature Version	Size	Regulated Pressure bar (psi)	Max Inlet Pressure bar	A	B	Weight kg	Cv
2PRVSV022A	2PRVSF022A	1/4"	0.50 to 2.0 (7.2 to 29)	20	24	M4	1.6	2.4
4PRVSV022A	4PRVSF022A	1/2"			28	M5	1.6	4.4
6PRVSV022A	6PRVSF022A	3/4"			---	---	1.8	5.0
2PRVSV042A	2PRVSF042A	1/4"	0.50 to 4.0 (7.2 to 58)	20	24	M4	1.6	2.4
4PRVSV042A	4PRVSF042A	1/2"			28	M5	1.6	4.4
6PRVSV042A	6PRVSF042A	3/4"			---	---	1.8	5.0
2PRVSV082A	2PRVSF082A	1/4"	0.50 to 8.0 (7.2 to 116)	20	24	M4	1.6	2.4
4PRVSV082A	4PRVSF082A	1/2"			28	M5	1.6	4.4
6PRVSV082A	6PRVSF082A	3/4"			---	---	1.8	5.0
2PRVSV122A	2PRVSF122A	1/4"	0.50 to 12.0 (7.2 to 174)	20	24	M4	1.6	2.4
4PRVSV122A	4PRVSF122A	1/2"			28	M5	1.6	4.4
6PRVSV122A	6PRVSF122A	3/4"			---	---	1.8	5.0

1/4" NPT gauge port option available - suffix product code with 'X'
 If ATEX certification is required suffix product code with 'ATEX'

3550 Series air service units – Accessories for ¼" to ¾" units - supplied separately

Plastic handwheel kit

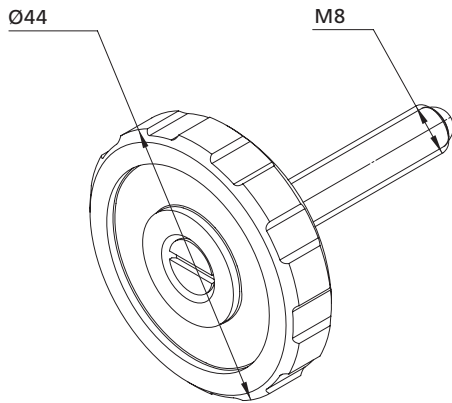

Product Code	Description
SSAF238/23	Kit comprises of 1 plastic handwheel, 1 pressure adjusting screw (316 stainless steel) and 1 hand-wheel retaining screw (316 stainless steel)

Stud mounting kit

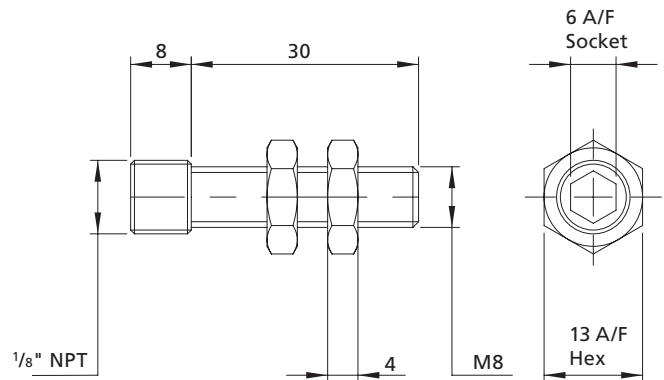

Product Code	Description
SSBF238/21	Kit comprises of 1 stud complete with 2 locknuts and is designed to screw into un-used gauge port. All components 316 stainless steel.

Mounting bracket

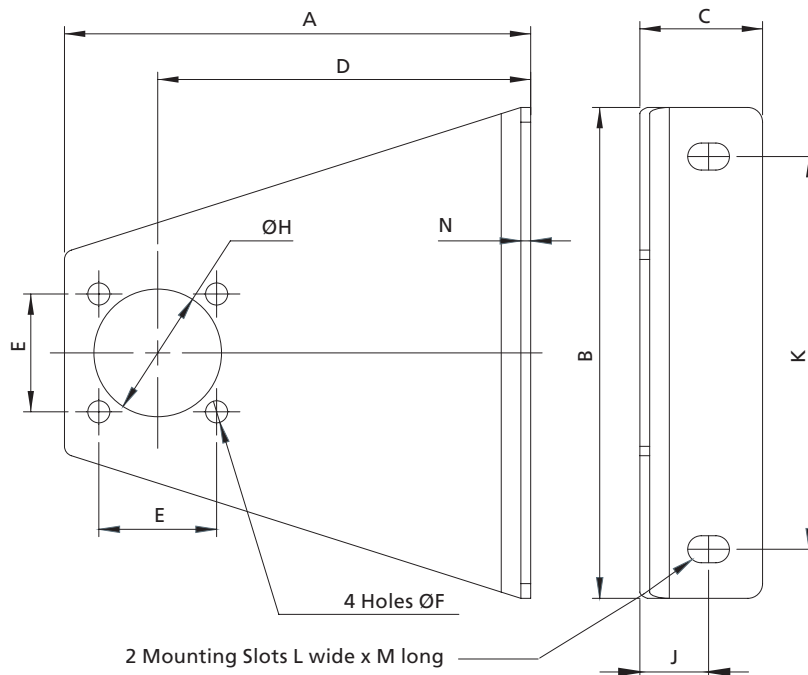

Product Code	Suitable for	A	B	C	D	E	F	H	J	K	L	M	N
SSF2110-7S	¼" units (Short)	79	100	25	60	24	4.5	26	14	80	5.5	8.5	2
SSF2110-7	¼" units (Long)	95	100	25	76	24	4.5	26	14	80	5.5	8.5	2
SSF4110-7	½", ¾" units	95	100	25	76	28	4.5	26	14	80	5.5	8.5	2

Component material 316 stainless steel. Brackets are supplied complete with fasteners.
Note: Part numbers above are for single items

3550 Series air service units – Accessories for 1/4" to 3/4" units - supplied separately

Pressure gauge SS-316L - Glycerine filled

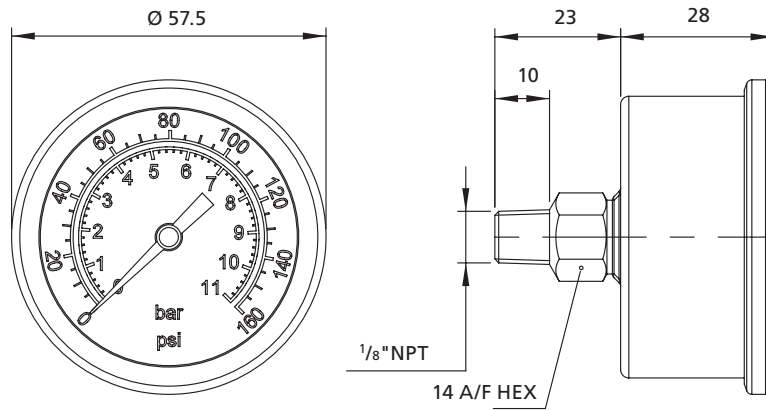

Product Code	Size mm	Regulated Pressure bar
SSF153N/2GLY	50	0 to 2
SSF153N/4GLY	50	0 to 4
SSF153N/11GLY	50	0 to 11

Please consult factory for low temperature version if required.

Tamperproof cap kit

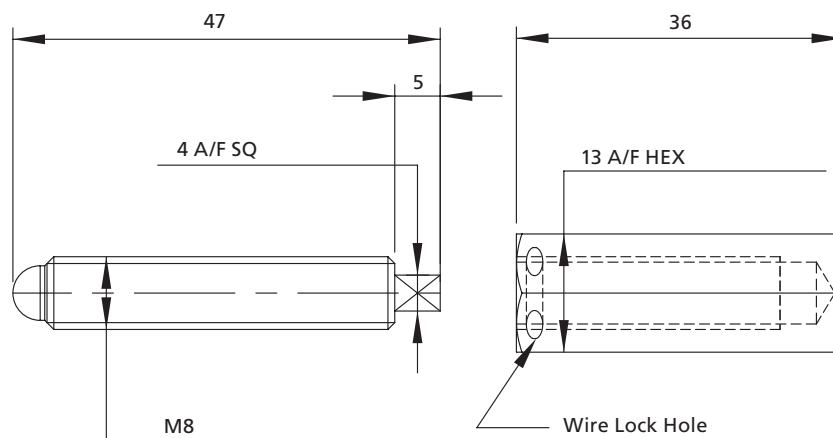

Product Code	Description
SSAF238/22	Kit comprises of 1 pressure adjusting screw and 1 tamperproof cap. All material 316 stainless steel

3500 Series air service units – 3/4" to 1" Filter Regulators

A 316L stainless steel combined unit for filtration and regulation of compressed air and gases for the actuation industries.

Features and Benefits

- Specifically designed for severe environments
- 40 micron element as standard, 5 micron option available
- Ambient temperature range -20 to +80 °C (-4 to +176 °F) Low temperature option available
- Non or self-relieving
- 316L stainless steel construction
- Large flow characteristics
- Bowl capacity window

Ambient Temperature Range

- Standard: -20 to +80 °C (-4 to +176 °F)¹
- Low temp: -50 to +80 °C (-58 to +176 °F)² optional

¹ When product is ordered as 'ATEX' ambient temperature range is -10 °C to +40 °C (14 °F to +104 °F) (T6) (EC Directive 94/9/EC).

² When product is ordered as 'ATEX' ambient temperature range is -50 °C to +40 °C (-58 °F to +104 °F) (T6) (EC Directive 94/9/EC).

Maximum Relief Flow

- At 2 bar (29 psi) secondary pressure
0.5 cc/sec (0.03 cu in/sec)

Flow

At 7 bar (102 psi) supply pressure, 6 bar (87 psi) secondary pressure, 1 bar (14.5 psi) pressure drop.

- 7,800 l/min (274 SCFM)

Maximum Inlet Pressure

- Manual drain - 20 bar (290 psi)
- Automatic drain - 17 bar (247 psi)

Ports NPT

(BSP option available - consult factory for part codes)

- 3/4", 1"

Gauge Ports

- 1/8" NPT



Relief Vent Port

- 1/8" NPT (fitted with breather)
Note: Not fitted on low temperature option

Bowl Capacity

- 260 cc (15.87 cu ins)

Accessories Available

- Mounting brackets
- Stainless steel pressure gauge

See page 28-29 for ordering details

Operating Media

- Gases - air, inert gas and sweet (natural) gases

Construction Materials

- Body/bonnet/bowl and internals: 316L stainless steel
Note: on auto-drain version float is nylon, polyoxymethylene and rubber.
- Element: 40 micron sintered polypropylene (5 micron option available - suffix product code with '05')
- Seals: Standard option - Fluoroelastomer
Low temperature option - EPDM

Certification Options Available



rotork[®]
Midland

3500 Series air service units – 3/4" to 1" Filter Regulators - Engineering Drawings (manual drain)

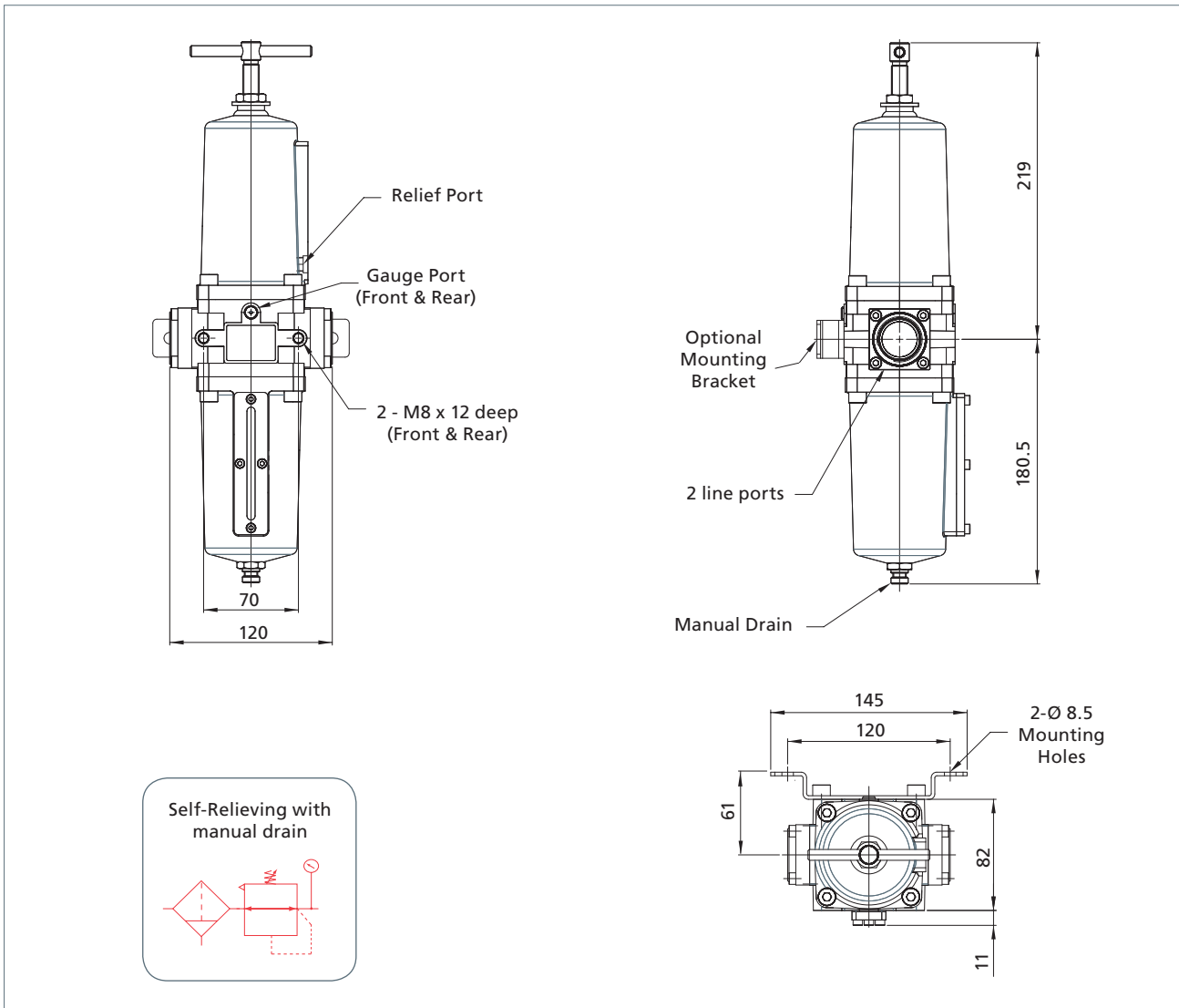

Product Code	Low Temperature Version	Size	Filter	Regulated Pressure bar (psi)	Max Inlet Pressure bar	Weight kg	Cv
6FRMSV022	6FRMSL022	3/4"	Manual Drain	0.50 to 2.0 (7.2 to 29)	20	5.75	6.5
8FRMSV022	8FRMSL022	1"				5.75	8.8
6FRMSV042	6FRMSL042	3/4"	Manual Drain	0.50 to 4.0 (7.2 to 58)	20	5.75	6.5
8FRMSV042	8FRMSL042	1"				5.75	8.8
6FRMSV072	6FRMSL072	3/4"	Manual Drain	0.50 to 7.0 (7.2 to 102)	20	5.75	6.5
8FRMSV072	8FRMSL072	1"				5.75	8.8
6FRMSV102	6FRMSL102	3/4"	Manual Drain	0.50 to 10.0 (7.2 to 145)	20	5.75	6.5
8FRMSV102	8FRMSL102	1"				5.75	8.8

5 micron option available - suffix product code with '05'.
 If ATEX certification is required suffix product code with 'ATEX'

3500 Series air service units – 3/4" to 1" Filter Regulators - Engineering Drawings (auto drain)

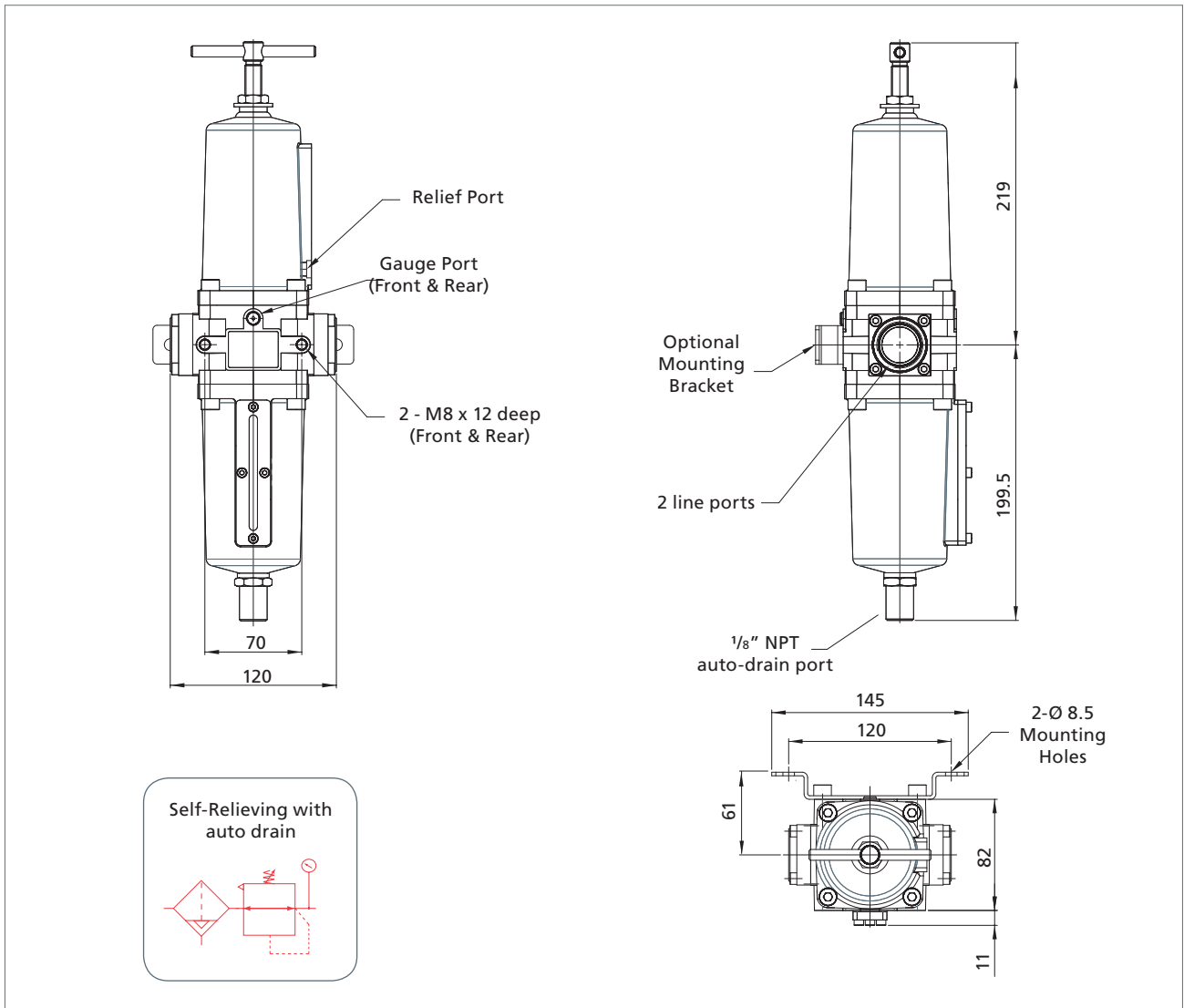

Product Code	Size	Filter	Regulated Pressure bar (psi)	Max Inlet Pressure bar	Weight kg	Cv
6FRASV022	3/4"	Auto Drain	0.50 to 2.0 (7.2 to 29)	17	5.75	6.5
8FRASV022	1"				5.75	8.8
6FRASV042	3/4"	Auto Drain	0.50 to 4.0 (7.2 to 58)	17	5.75	6.5
8FRASV042	1"				5.75	8.8
6FRASV072	3/4"	Auto Drain	0.50 to 7.0 (7.2 to 102)	17	5.75	6.5
8FRASV072	1"				5.75	8.8
6FRASV102	3/4"	Auto Drain	0.50 to 10.0 (7.2 to 145)	17	5.75	6.5
8FRASV102	1"				5.75	8.8

Low temperature version not available in auto drain. 5 micron option available - suffix product code with '05'.
If ATEX certification is required suffix product code with 'ATEX'

3500 Series air service units – 3/4" to 1" Filters

A 316L stainless steel unit for filtration of compressed air and gases for the actuation industries.

Features and Benefits

- Specifically designed for severe environments
- 40 micron element as standard, 5 micron option available
- Ambient temperature range -20 to +80 °C (-4 to +176 °F) Low temperature option available
- 316L stainless steel construction
- Large flow characteristics
- Bowl capacity window

Ambient Temperature Range

- Standard: -20 to +80 °C (-4 to +176 °F)¹
- Low temp: -50 to +80 °C (-58 to +176 °F)² optional

¹ When product is ordered as 'ATEX' ambient temperature range is -10 °C to +40 °C (14 °F to +104 °F) (T6) (EC Directive 94/9/EC).

² When product is ordered as 'ATEX' ambient temperature range is -50 °C to +40 °C (-58 °F to +104 °F) (T6) (EC Directive 94/9/EC).

Flow

At 7 bar (102 psi) supply pressure, 0.35 bar (5 psi) pressure drop.

- 10,020 l/min (353 SCFM)

Maximum Inlet Pressure

- Manual drain - 20 bar (290 psi)
- Automatic drain - 17 bar (247 psi)

Ports NPT

(BSP option available - consult factory for part codes)

- 3/4", 1"

Bowl Capacity

- 260 cc (15.87 cu ins)

Operating Media

- Gases - air, inert gas and sweet (natural) gas

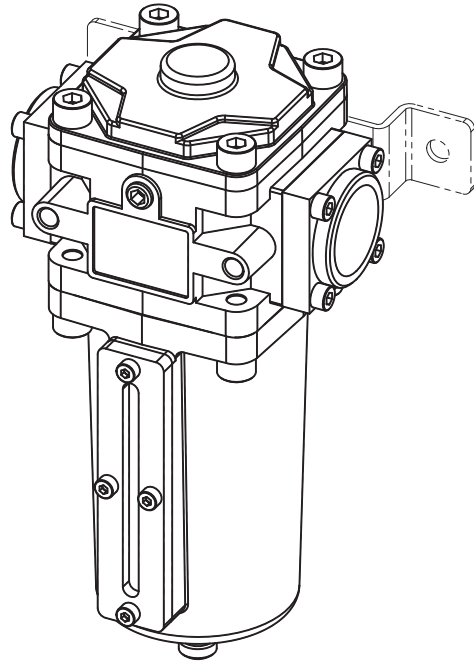

Construction Materials

- Body/bonnet/bowl and internals: 316L stainless steel
Note: on auto-drain version float is nylon, polyoxymethylene and rubber.
- Element: 40 micron sintered polypropylene (5 micron option available - suffix product code with '05')
- Seals: Standard option - Fluoroelastomer
Low temperature option - EPDM

Accessories Available

- Mounting brackets

See page 29 for ordering details

Certification Options Available



3500 Series air service units – 3/4" to 1" Filters - Engineering Drawings (manual drain)

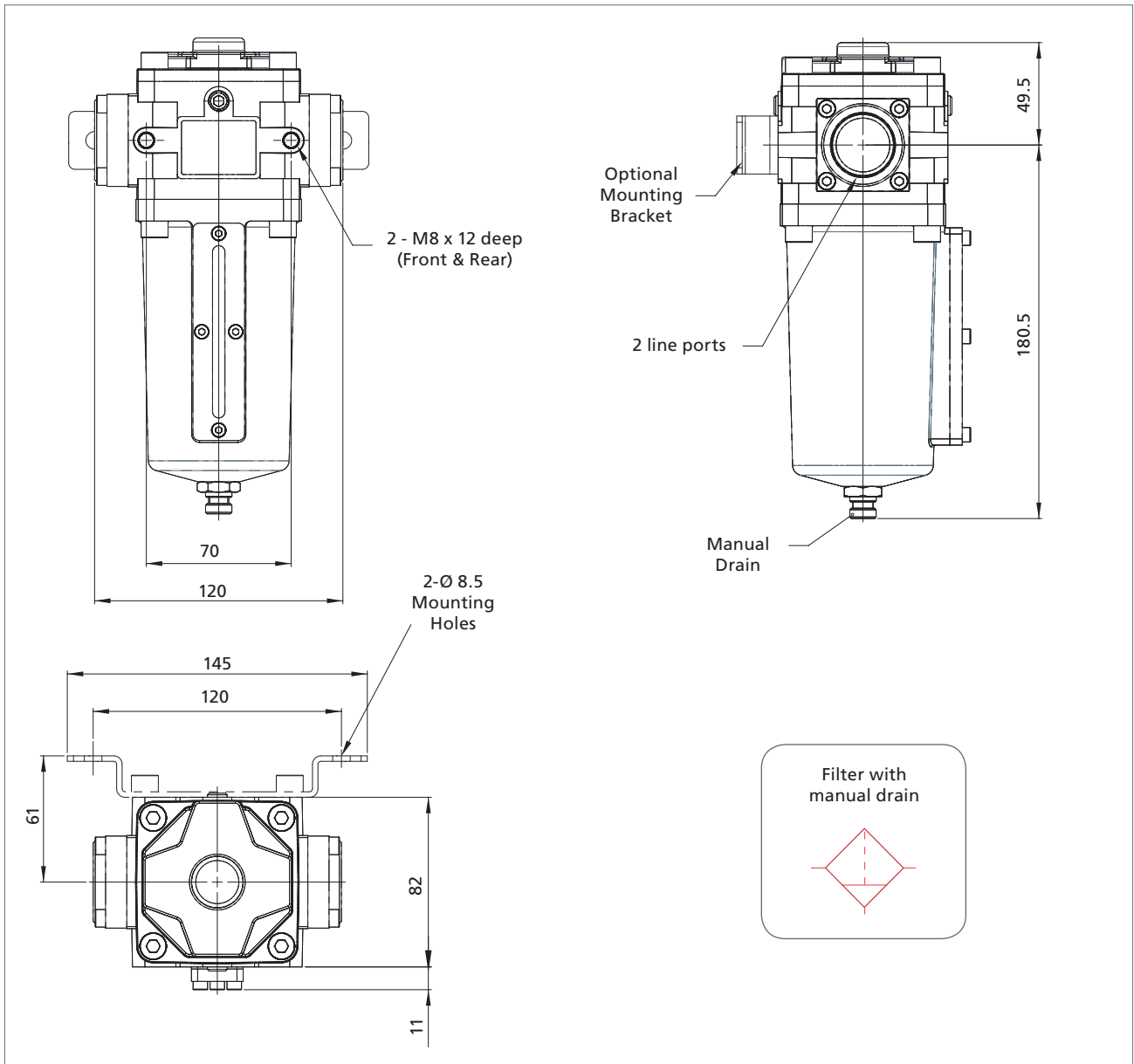

Product Code	Low Temperature Version	Size	Filter	Max Inlet Pressure bar	Weight kg	Cv
6FLMSV202	6FLMSL202	3/4"	Manual Drain	20	3.75	6.5
8FLMSV202	8FLMSL202	1"			3.75	8.8

5 micron option available - suffix product code with '05'
 If ATEX certification is required suffix product code with 'ATEX'.

rotork[®]
Midland

3500 Series air service units – 3/4" to 1" Filters - Engineering Drawings (auto drain)

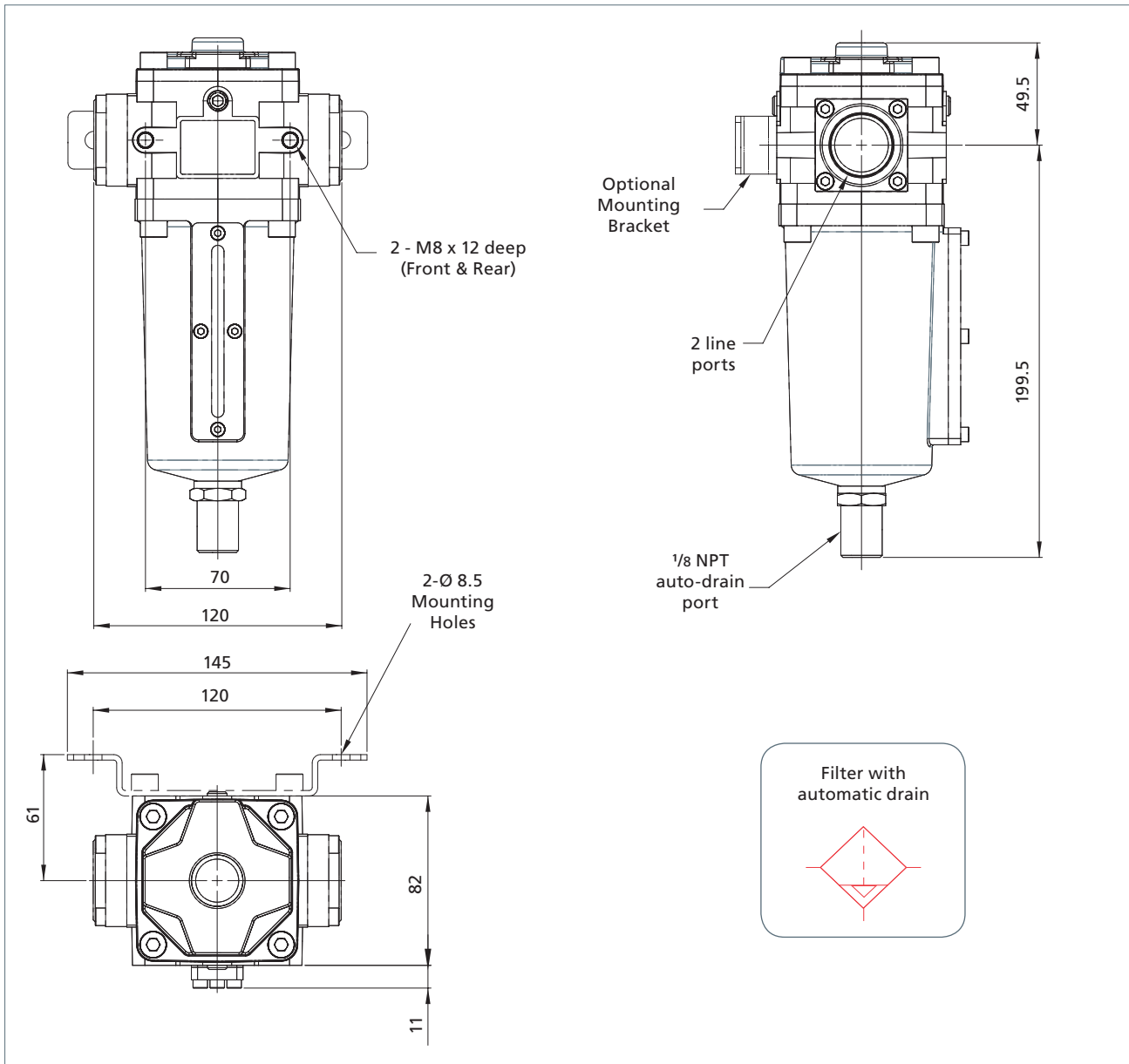

Product Code	Size	Filter	Max Inlet Pressure bar	Weight kg	Cv
6FLASV172	3/4"	Auto Drain	17	3.75	6.5
8FLASV172	1"			3.75	8.8

Low temperature version not available in auto drain. 5 micron option available - suffix product code with '05'.
 If ATEX certification is required suffix product code with 'ATEX'

3500 Series air service units – 3/4" to 1" Filters - Flow Characteristics

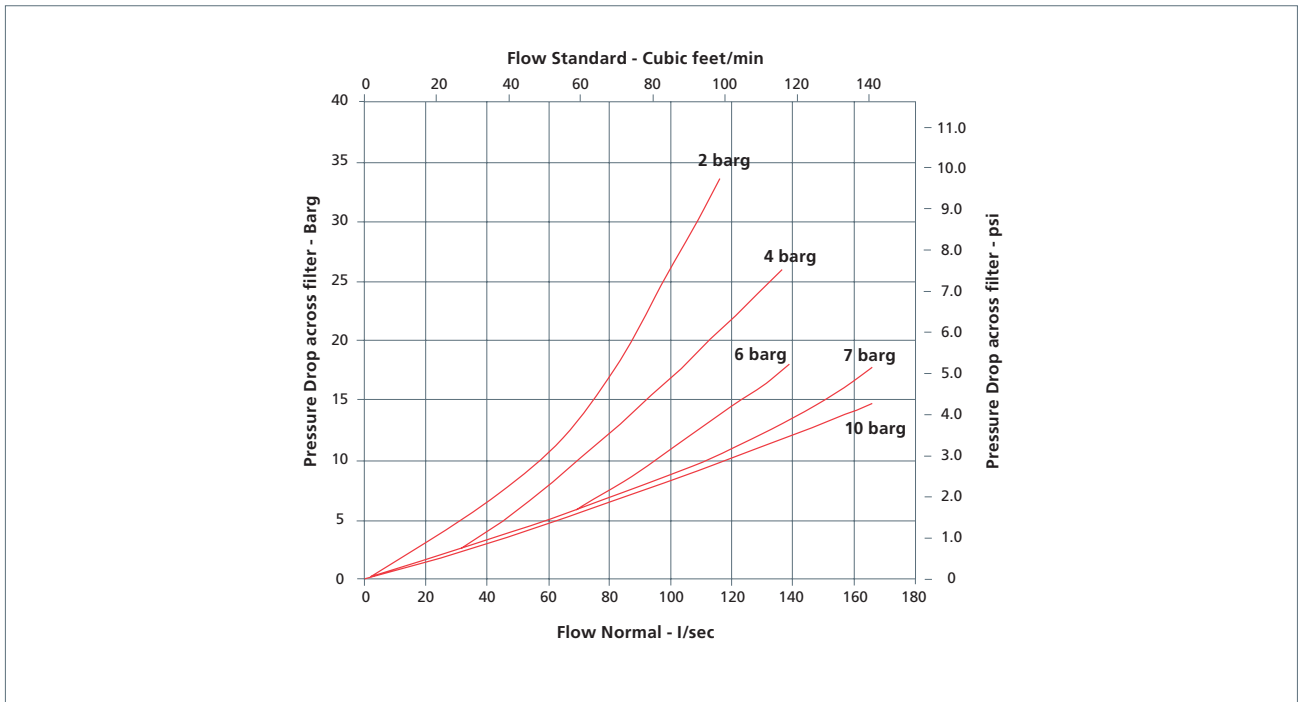

rotork[®]
Midland

3500 Series air service units – 3/4" to 1" Pressure Regulators

A 316L stainless steel unit for pressure regulation of compressed air and gases for the actuation industries.

Features and Benefits

- Specifically designed for severe environments
- Non or self-relieving
- Ambient temperature range -20 to +80 °C (-4 to +176 °F)
Low temperature option available
- 316L stainless steel construction
- Large flow characteristics

Ambient Temperature Range

- Standard: -20 to +80 °C (-4 to +176 °F)¹
- Low temp: -50 to +80 °C (-58 to +176 °F)² optional

¹ When product is ordered as 'ATEX' ambient temperature range is -10 °C to +40 °C (14 °F to +104 °F) (T6) (EC Directive 94/9/EC).

² When product is ordered as 'ATEX' ambient temperature range is -50 °C to +40 °C (-58 °F to +104 °F) (T6) (EC Directive 94/9/EC).

Maximum Relief Flow

- At 2 bar (29 psi) secondary pressure
0.5 cc/sec (0.03 cu in/sec)

Flow

At 7 bar (102 psi) supply pressure, 6 bar (87 psi) secondary pressure, 1 bar (14.5 psi) pressure drop.

- 7,800 l/min (274 SCFM)

Ports NPT

(BSP option available - consult factory for part codes)

- 3/4", 1"

Gauge Ports

- 1/8" NPT

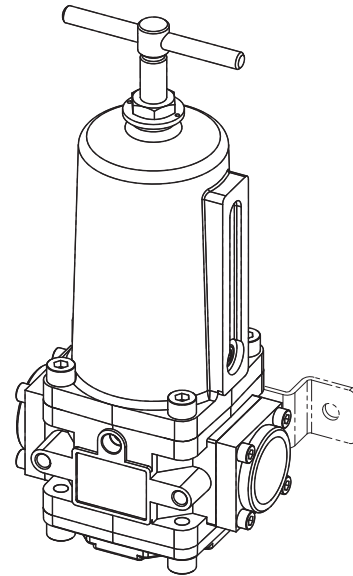

Relief Vent Port

- 1/8" NPT (fitted with breather)
Note: Not fitted on low temperature option

Operating Media

- Gases - air, inert gas, sweet (natural) gas

Construction Materials

- Body/bonnet/bowl and internals: 316L stainless steel
- Seals: Standard option - Fluoroelastomer
Low temperature option - EPDM

Accessories Available

- Mounting brackets
- Stainless steel pressure gauge

See page 28-29 for ordering details

Product Code	Low Temperature Version	Size	Regulated Pressure bar (psi)	Max Inlet Pressure bar	Weight kg	Cv
6PRVSV022	6PRVSL022	3/4"	0.50 to 2.0 (7.2 to 29)	20	5.0	6.5
8PRVSV022	8PRVSL022	1"				8.8
6PRVSV042	6PRVSL042	3/4"	0.50 to 4.0 (7.2 to 58)	20	5.0	6.5
8PRVSV042	8PRVSL042	1"				8.8
6PRVSV072	6PRVSL072	3/4"	0.50 to 7.0 (7.2 to 102)	20	5.0	6.5
8PRVSV072	8PRVSL072	1"				8.8
6PRVSV102	6PRVSL102	3/4"	0.50 to 10.0 (7.2 to 145)	20	5.0	6.5
8PRVSV102	8PRVSL102	1"				8.8

If ATEX certification is required suffix product code with 'ATEX'

Certification Options Available



3500 Series air service units — 3/4" to 1" Pressure Regulators - Engineering Drawings & Flow Characteristics

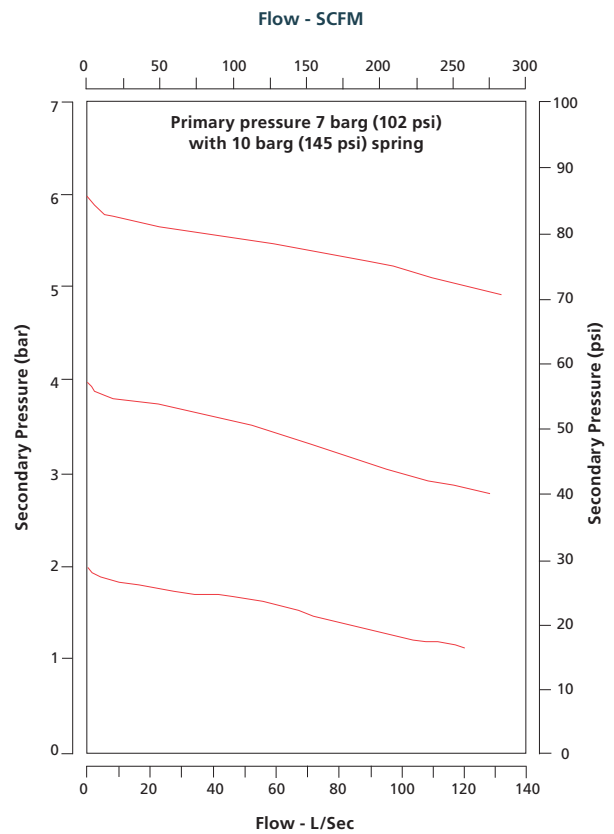
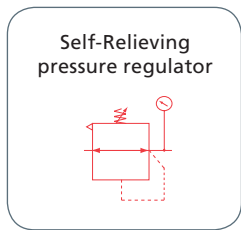
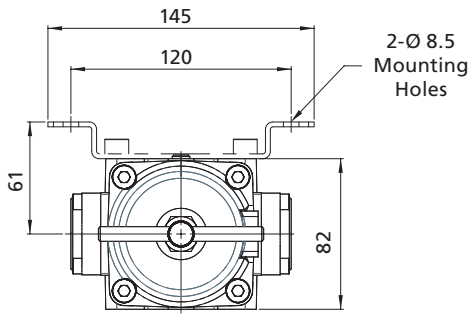
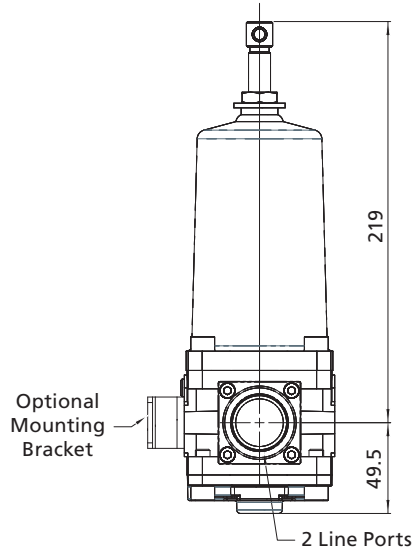
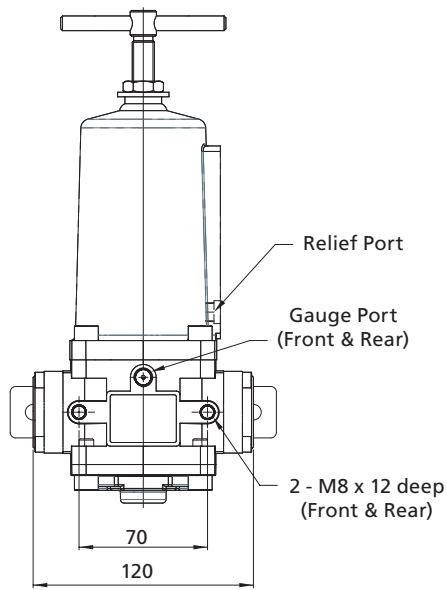

3500 Series air service units – 1/2" Lubricator

A 316L stainless steel unit providing lubrication of compressed air for the actuation industries.

Features and Benefits

- Specifically designed for severe environments
- Accurate drip rate adjustment
- Can be filled under pressure
- Transparent sight feed dome
- Ambient temperature range -20 to +80 °C (-4 to +176 °F)
- 316L stainless steel construction
- Built in flow sensor to automatically adjust lubrication delivery to meet wide air flow demand

Ambient Temperature Range

- Standard: -20 to +80 °C (-4 to +176 °F)¹

¹ When product is ordered as 'ATEX' ambient temperature range is -10 °C to +40 °C (14 °F to +104 °F) (T6) (EC Directive 94/9/EC).

Working Pressure

- 17 bar (247 psi)

Ports NPT

(BSP option available - consult factory for part codes)

- 1/2" NPT

Bowl Capacity

- 380 cc (23.2 cu ins)

Operating Media

- Gases - air, inert gas and sweet (natural) gases

Construction Materials

- Body/bonnet/bowl and internals: stainless steel 316L
- Seals: Nitrile
- Bowl: 316 stainless steel
- Acrylic flow and sight glass

Product Code

- 4LUBSN172

If ATEX certification is required suffix product code with 'ATEX'

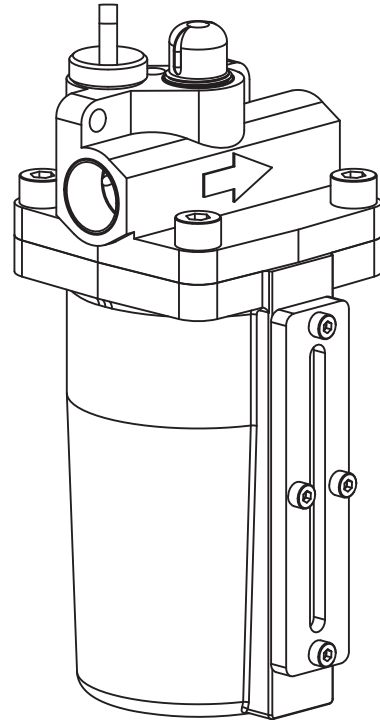

3500 Series air service units — 1/2" Lubricator - Engineering Drawings

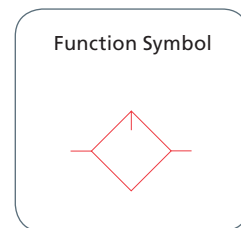
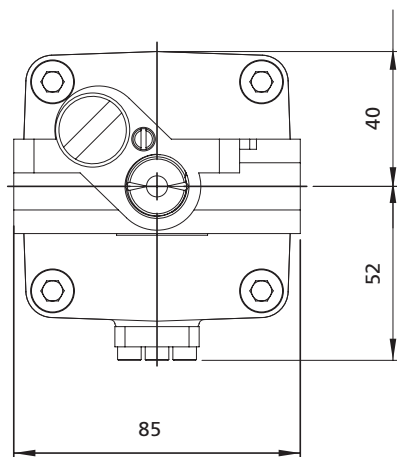
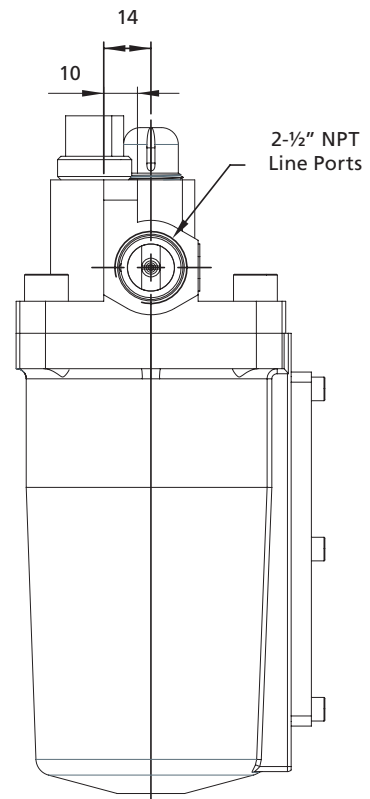
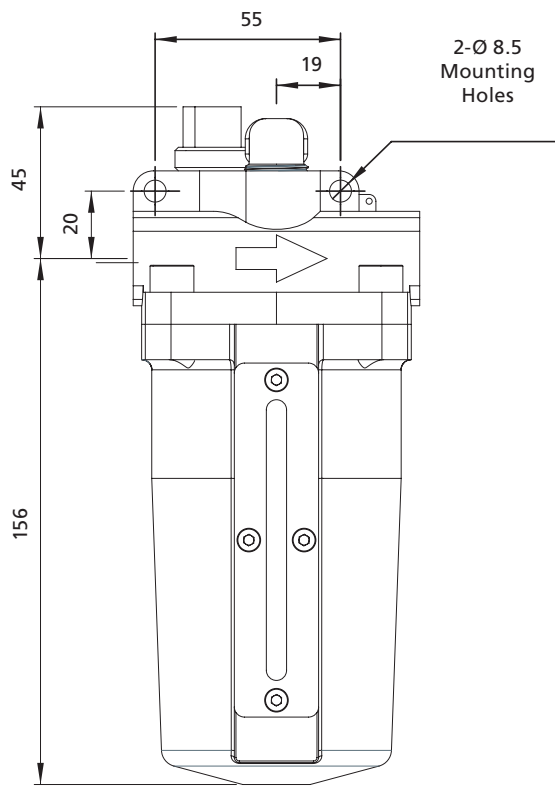

rotork[®]
Midland

3500 Series air service units — Accessories for ¾" to 1" units - supplied separately

Pressure gauge SS-316L - Glycerine filled

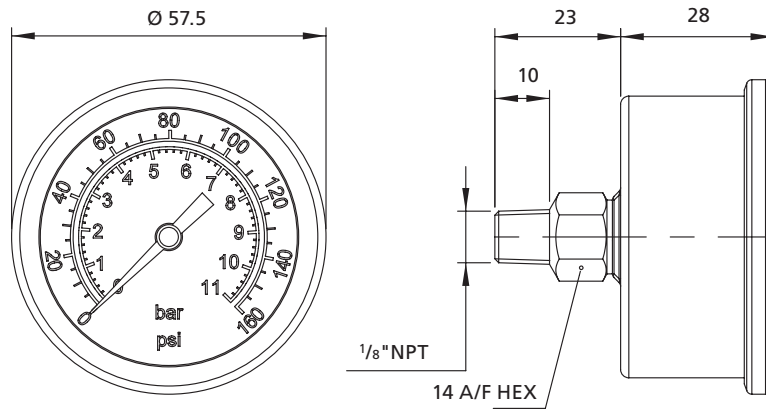

Product Code	Size mm	Regulated Pressure bar
SSF153N/2GLY	50	0 to 2
SSF153N/4GLY	50	0 to 4
SSF153N/11GLY	50	0 to 11

Please consult factory for low temperature version if required.

Tamperproof cap kit

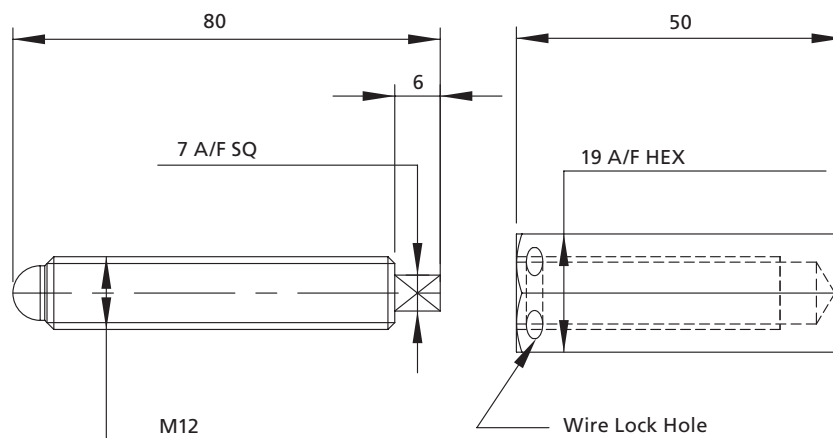

Product Code	Description
SSAF638/22	Kit comprises of 1 pressure adjusting screw and 1 tamperproof cap. All material stainless steel

3500 Series air service units – Accessories for ¾" to 1" units - supplied separately

Mounting bracket

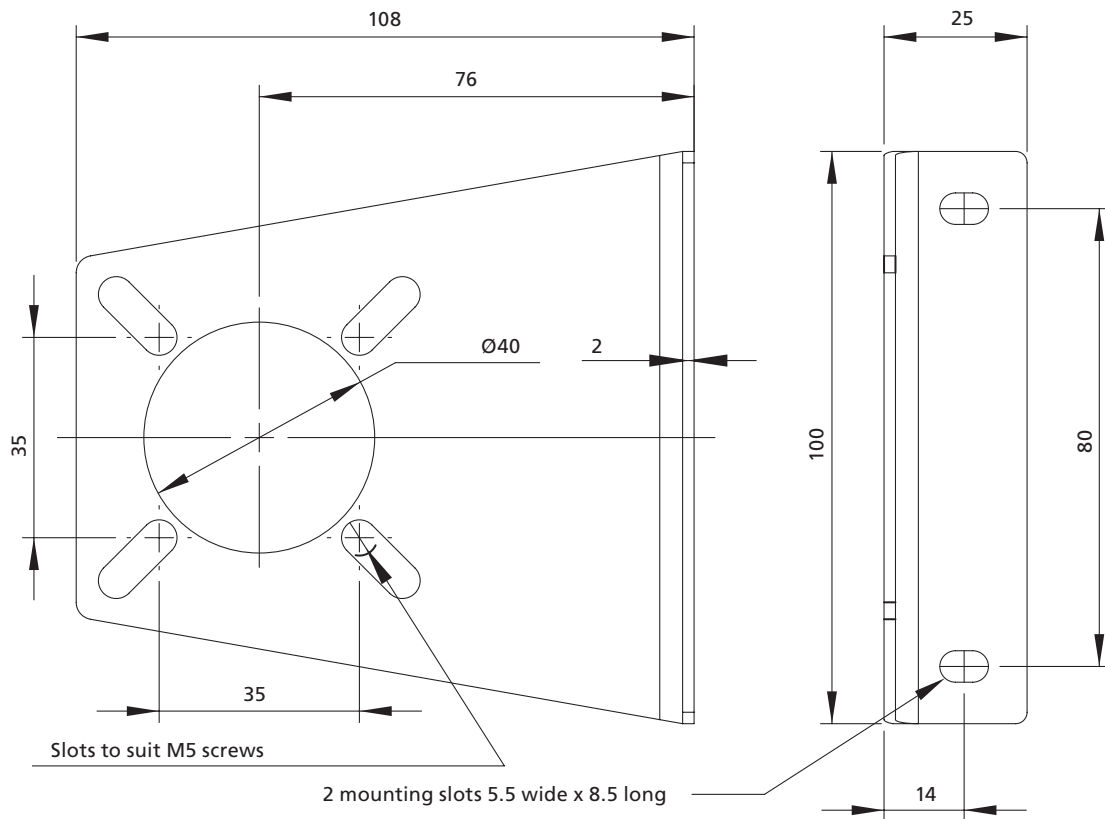

Filter / Regulator with Mounting Brackets

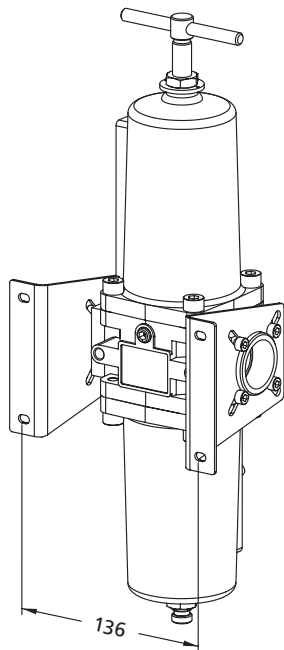

Product Code	Suitable for
SSF8110-7	¾" & 1" units

Component material 316 stainless steel.
 Brackets are supplied complete with fasteners.
Note: Part number above is for single item.

rotork[®]
 Midland

3500 Series air service units — Accessories for 3/4" to 1" units - supplied separately

Rear mounting bracket

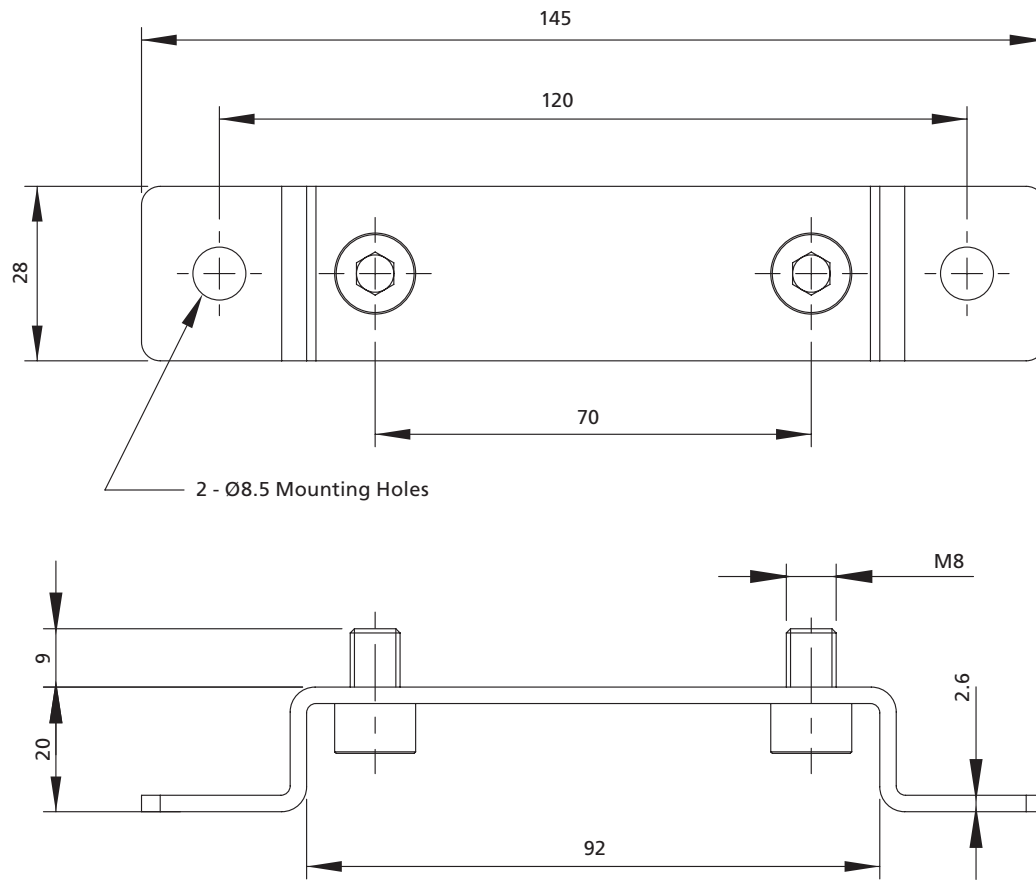

Filter / Regulator with Rear Bracket

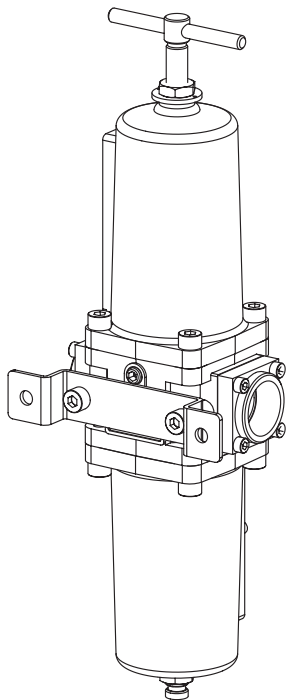

Product Code	Description
SSAF638-26	Kit comprises of 1 mounting bracket and 2 - M8 x12 cap head screws. All material stainless steel.

3575 Series air service units – 1½" to 2" Filter Regulators

A 316L stainless steel combined unit for filtration and regulation of compressed air and gases for the actuation industries.

Features and Benefits

- Specifically designed for severe environments
- Self-relieving
- Manual or auto-drain
- 25 micron element stainless steel 316
- Ambient temperature range -20 to +80 °C (-4 to +176 °F)
- 316L stainless steel construction
- Mounting brackets supplied fitted as standard
- Gauge supplied fitted as standard
- Regulated pressure range from 0.50 to 12.0 bar depending on model selection
- Option available to supply without pilot regulator (consult factory for product code)
- Large flow paths (up to 45 Cv)
- NACE capability option available, manual drain only (consult factory)

Units ordered with a specified pressure range will be supplied complete with a pilot regulator and piped using double ferrule fittings.

Ports NPT

(BSP option available - consult factory for part codes)

- 1½", 2"

Gauge Ports

- 1/8" NPT (fitted with gauge)

Relief Vent Port

- 1/2" NPT (fitted with breather)

Maximum Relief Flow

- At 2 bar (29 psi) secondary pressure
0.5 cc/sec (0.03 cu in/sec)



Flow

At 10 bar (145 psi) supply pressure, 6 bar (87 psi) secondary pressure, 1 bar (14.5 psi) pressure drop.

- 2" - 45,000 l/min (1,590 SCFM)

Bowl Capacity

- 21 cc (1.28 cu ins)

Operating Media

- Gases - air, inert gas, sour gases - NACE option available (consult factory)

Construction Materials

- Body/bonnet/bowl and internals: 316L stainless steel
Note: on auto-drain version float is nylon, polyoxymethylene and rubber.
- Element: 25 micron 316 stainless steel
- Seals: Nitrile

rotork[®]
Midland

3575 Series air service units – 1½" to 2" Filter Regulators - Engineering Drawings

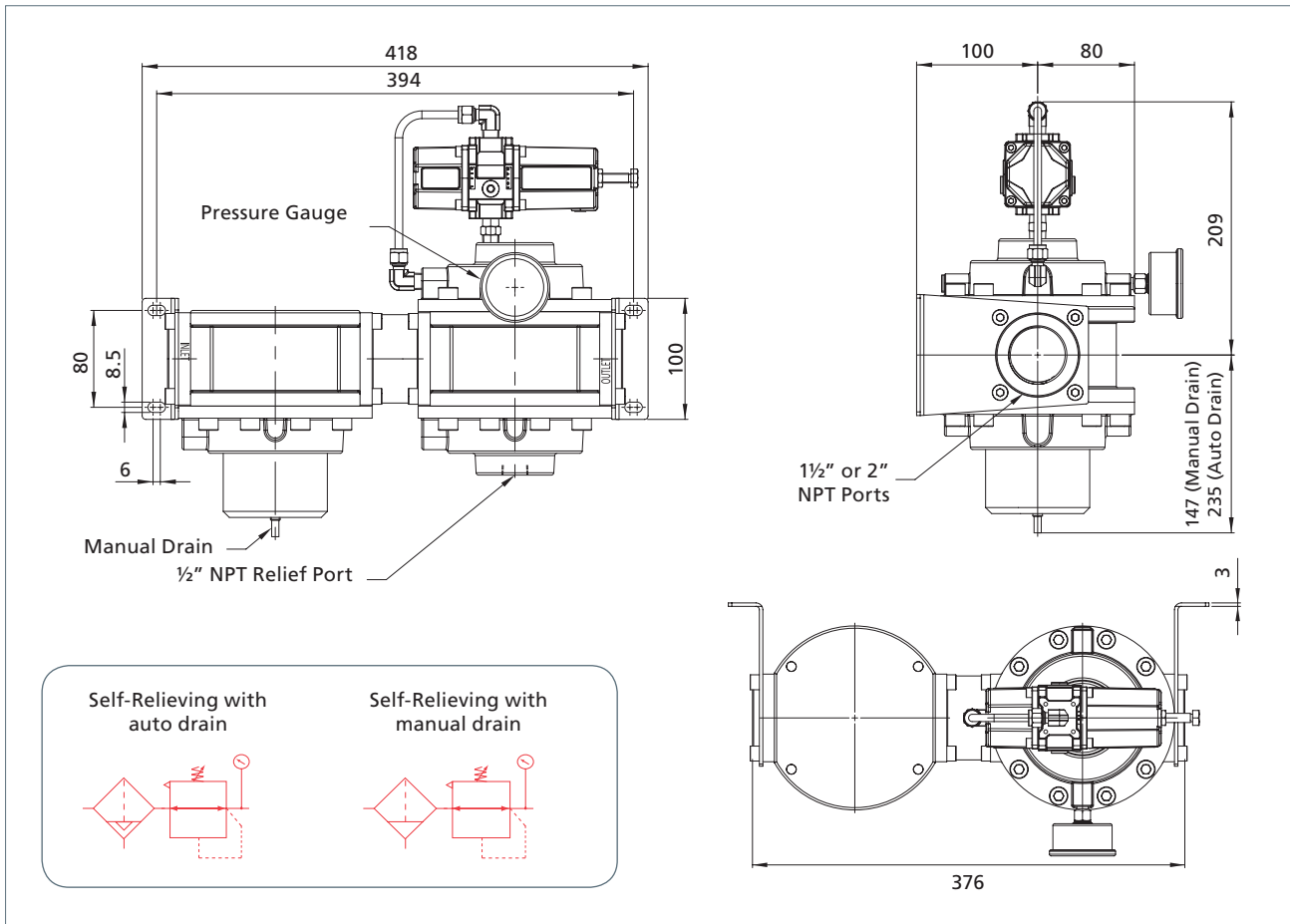

Product Code	Size	Filter	Regulated Pressure bar (psi)	Max Inlet Pressure bar	Weight kg	Cv	
7FRMSN022	1½"	Manual Drain	0.50 to 2.0 (7.2 to 29)	20	19	38	
9FRMSN022	2"					45	
7FRASN022	1½"	Auto Drain		17		38	
9FRASN022	2"					45	
7FRMSN042	1½"	Manual Drain		0.50 to 4.0 (7.2 to 58)		20	38
9FRMSN042	2"						45
7FRASN042	1½"	Auto Drain	17		38		
9FRASN042	2"				45		
7FRMSN082	1½"	Manual Drain	0.50 to 8.0 (7.2 to 116)		20	38	
9FRMSN082	2"					45	
7FRASN082	1½"	Auto Drain		17	38		
9FRASN082	2"				45		
7FRMSN122	1½"	Manual Drain		0.50 to 12.0 (7.2 to 174)	20	38	
9FRMSN122	2"					45	
7FRASN122	1½"	Auto Drain	17		38		
9FRASN122	2"				45		

3575 Series air service units – 1½” to 2” Filter

A 316L stainless steel compressed air filter, designed to provide clean air for the actuation industries.

Features and Benefits

- Specifically designed for severe environments
- Manual or auto-drain
- 25 micron element stainless steel 316
- Ambient temperature range -20 to +80 °C (-4 to +176 °F)
- 316L stainless steel construction
- Mounting brackets supplied fitted as standard
- Large flow paths (up to 45 Cv)
- NACE capability option available, manual drain only (consult factory)

Ports NPT

(BSP option available - consult factory for part codes)

- 1½”, 2”

Flow

At 6 bar (87 psi) supply pressure, 1 bar (14.5 psi) pressure drop.

- 2” - 45,000 l/min (1,590 SCFM)

Bowl Capacity

- 21 cc (1.28 cu ins)

Operating Media

- Gases - air, inert gas, sour gases - NACE option available (consult factory)

Construction Materials

- Body/bonnet/bowl and internals: 316L stainless steel
Note: on auto-drain version float is nylon, polyoxymethylene and rubber.
- Element: 25 micron 316 stainless steel
- Seals: Nitrile



Product Code	Size	Filter	Max Inlet Pressure bar	Weight kg	Cv
7FLMSN202	1½”	Manual Drain	20	8.7	38
9FLMSN202	2”			8.7	45
7FLASN172	1½”	Auto Drain	17	8.7	38
9FLASN172	2”			8.7	45

rotork[®]
Midland

3575 Series air service units – 1½" to 2" Filters - Engineering Drawings

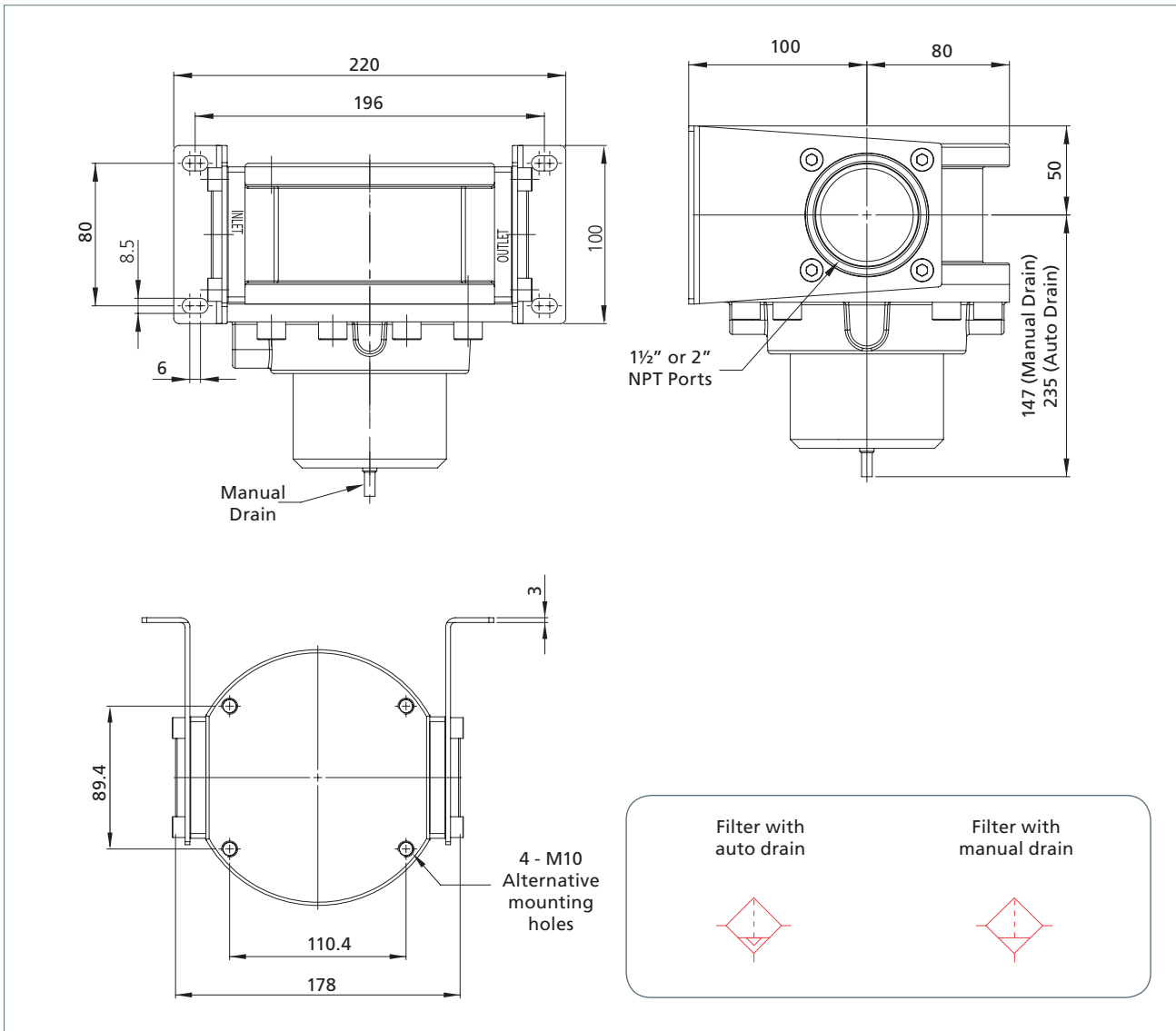

3575 Series air service units – 1½" to 2" Pressure Regulators

A 316L stainless steel unit for pressure regulation of compressed air and gases for the actuation industries.

Features and Benefits

- Specifically designed for severe environments
- Self-relieving
- Ambient temperature range -20 to +80 °C (-4 to +176 °F)
- 316L stainless steel construction
- Mounting brackets supplied fitted as standard
- Gauge fitted as standard
- Regulated pressure range from 0.50 to 12.0 bar depending on model selection
- Large flow paths (up to 45 Cv)
- Option available to supply without pilot regulator (consult factory for product code)
- NACE capability option available (consult factory)

Units ordered with a specified pressure range will be supplied complete with a pilot regulator piped using double ferrule fittings.

Ports NPT

(BSP option available - consult factory for part codes)

- 1½", 2"

Gauge Ports

- 1/8" NPT (fitted with gauge)

Relief Vent Port

- 1/2" NPT (fitted with breather)

Maximum Relief Flow

- At 2 bar (29 psi) secondary pressure
0.5 cc/sec (0.03 cu in/sec)



Flow

At 10 bar (145 psi) supply pressure, 6 bar (87 psi) secondary pressure, 1 bar (14.5 psi) pressure drop.

- 2" - 45,000 l/min (1,590 SCFM)

Operating Media

- Gases - air, inert gas, sour gases - NACE option available (consult factory)

Construction Materials

- Body/bonnet/bowl and internals: 316L stainless steel
Note: on auto-drain version float is nylon, polyoxymethylene and rubber.
- Seals: Nitrile

Product Code	Size	Regulated Pressure	Max Inlet Pressure bar	Weight kg	Cv
7PRVSN022	1½"	0.50 to 2.0 bar (7.2 to 29 psi)	20	11	38
9PRVSN022	2"				45
7PRVSN042	1½"	0.50 to 4.0 bar (7.2 to 58 psi)			38
9PRVSN042	2"				45
7PRVSN082	1½"	0.50 to 8.0 bar (7.2 to 116 psi)			38
9PRVSN082	2"				45
7PRVSN122	1½"	0.50 to 12.0 bar (7.2 to 174 psi)			38
9PRVSN122	2"				45

rotork[®]
Midland

3575 Series air service units — 1½" to 2" Pressure Regulators - Engineering Drawings

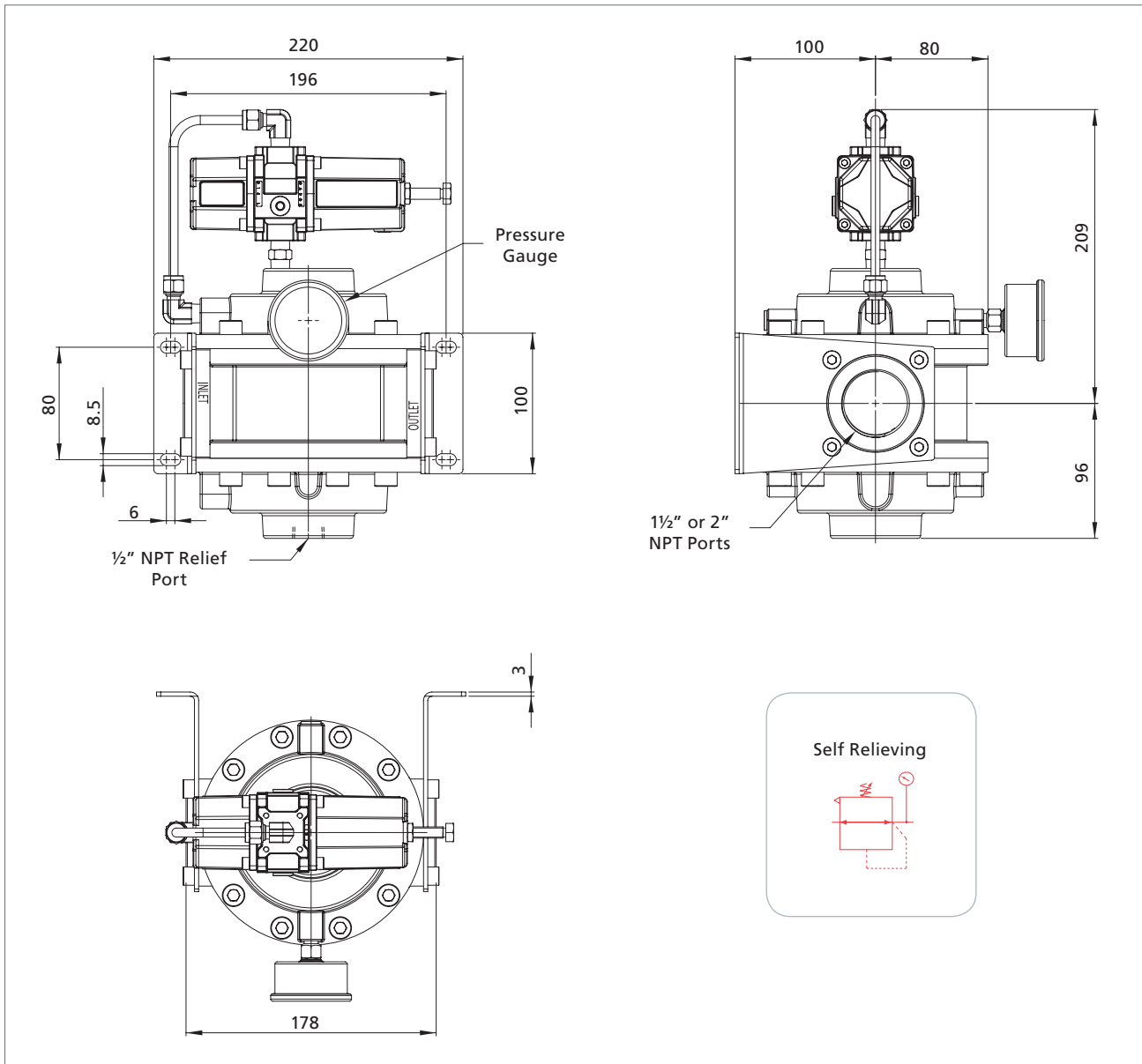

Over Pressurisation Device – OPD

A 316L stainless steel unit providing protection to downstream equipment from over pressure events.

Features and Benefits

- Protection of equipment from regulator failure and over pressure events
- Specifically designed for severe environments
- Manifold mounted option
- Auto shut-off
- ¼ turn actuator and on/off valve protection
- Linear actuator and control valve protection
- System instrumentation equipment protection
- Process valve stem & seat saver
- Easy installation
- 316L stainless steel construction
- Compliments and protects ESD & safety instrumented system equipment
- Ambient temperature range -20 to +80 °C (-4 to +176 °F)
Low temperature option available

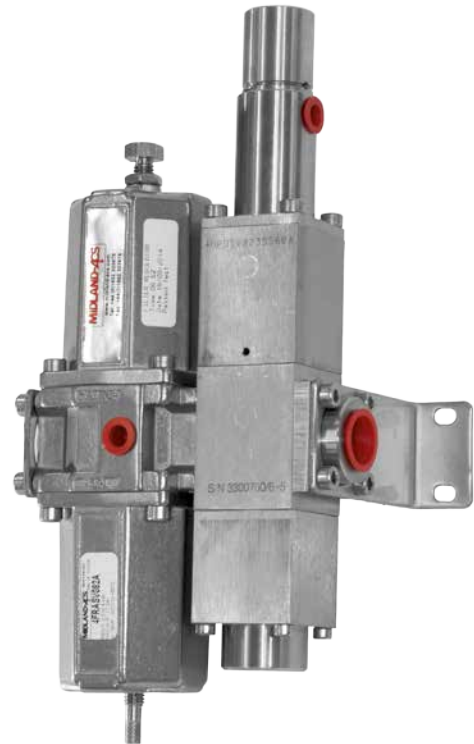

Regulated outlet pressure range

- 4 - 8 bar

Trip Pressure Range

- 4.5 - 8.5 bar (4-8 bar)

Maximum Response Time

- 30 ms (4-8 bar)

Temperature Range

- Standard: -20 to +80 °C (-4 to +176 °F)
- Low temp: -50 to +80 °C (-58 to +176 °F) optional

Maximum Inlet Pressure

- Manual drain: 20 bar
- Auto drain: 17 bar

Product Code (Manual Drain)	Product Code (Auto Drain)	Size	Weight kg
4OPDSVX23XX XXA	4OPASVX23XX XXA	½"	3.3

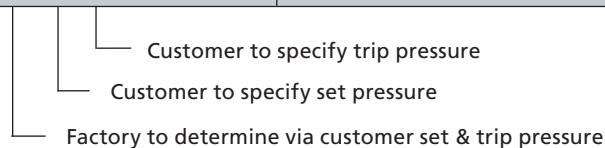

rotork[®]
Midland

Over Pressurisation Device – OPD

General Description

The purpose of the OPD is to protect downstream equipment from over pressure events including regulator failure, thus preventing potential damage and downtime. Applications include the protection of ESD & Safety Instrumented Systems including positioners, actuators and process valve stems. The device includes a pressure regulator with a protection valve and sensor system.

Increases in outlet pressure can occur for many reasons, including failure of key regulator components or misadjustment. Should this occur the device will automatically fail-safe within 30 milli-seconds. The protection valve will be triggered to shut-off the outlet and vent the downstream pressure.

When the protection valve has deployed, the reset button protrudes from the housing providing a positive indication that a fault has occurred. The OPD reduces the potential for damage occurring from increased torque, thrust or pressure values within the downstream system. Once the fault has been corrected the unit can be reset by pushing the reset button on the unit. In line with today's requirements for space saving, weight reduction and efficiency the system is all close coupled within a compact body.



Development

Failures of pressure regulators can result in the over pressurisation of the downstream line, as the self-relieving capacity of the regulator is insufficient to cope with major failures. Usually a relief valve of sufficient capacity is fitted into the system to hold the pressure down to an acceptable level.

However a relief valve flow is sized on a pressure differential between set pressure and over pressure, usually 10%. Thus on a set pressure of 4.5 barg a pressure rise to 4.95 barg would have to flow sufficiently to hold the pressure at 4.95 barg, against the flow through a failed pressure regulator. At 10 barg supply pressure the flow through the failed pressure regulators will be driven by a 10 to 4.95 i.e. 5.05 barg pressure drop. In many cases this would result in damage to sensitive & expensive equipment such as positioners, actuator diaphragms and process valve stems. An alternative is to fit an excessively large relief valve(s), which in itself could cause serious problems by dumping all of the systems air and starving other equipment resulting in plant shutdown and potential compressor damage.

Considered Regulator Failure modes

Failure modes are common to all manufacturers' regulators unless specific design changes have been made to cope with them. Therefore to overcome these difficulties the Over Pressurisation Device was designed and engineered.

Typical Regulator Failure Modes

- Misuse and maladjustment during installation and commissioning.
- Rupture of diaphragm leading to total loss of pressure regulation.
- Failure of regulator seat leading to partial or total loss of pressure regulation.
- Blocking of the regulator relief port leading to total loss of pressure regulation.



Over Pressurisation Device – OPD

Performance Characteristics

Response times are dependant upon the actual pressures within the system at the point of failure; all times stated within the specification section are maximums taken at the lowest extreme of the pressure range (worst case).

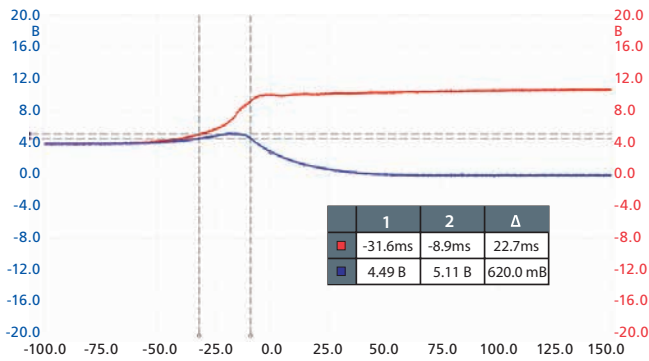

The magnitude of any pressure spikes exceeding the trip pressure which occur during deployment of the valve are dependant upon the system downstream volume; a larger system volume decreases the likelihood of the system pressure exceeding the trip pressure (see graphs). Any pressure spikes which do occur will only do so for a fraction of a second (less than the time taken for the device to operate).

Small actuator test results.

- 4-8 bar OPD; outlet connected to a volume of 0.2 litres

Trigger Test:

- **Blue** = Simulated actuator pressure (bar)
- **Red** = Supply pressure (bar)

The graph to the left is an overpressure test result with a small 0.2 litre reservoir to simulate the actuator. An overpressure signal is applied allowing the 11 barg supply pressure to bypass the regulator, simulating a ruptured diaphragm. The response time of the device is measured as the time between the pressure within the device reaching the trip pressure and the actuator pressure returning to below the regulated pressure (see dashed lines on graph & right hand column of table).

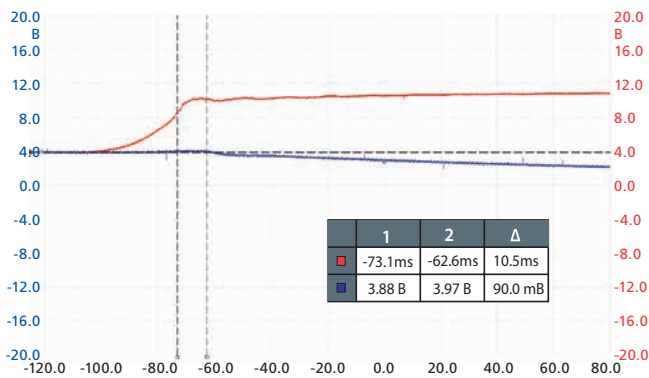

Larger actuator test results.

- 4-8 bar OPD; outlet connected to a volume of 3 litres

Trigger Test:

- **Blue** = Actuator pressure (bar)
- **Red** = Supply pressure (bar)

The graph above is an overpressure test result with a larger 3 litre reservoir to simulate the actuator. An overpressure signal is applied allowing the 11 barg supply pressure to bypass the regulator, simulating a ruptured diaphragm. The response time of the device is measured as the time between the pressure within the device reaching the trip pressure and the actuator pressure returning to below the regulated pressure (see dashed lines on graph & right hand column of table).

Note: During this test the actuator pressure does not exceed the trip pressure value.

Test Circuit

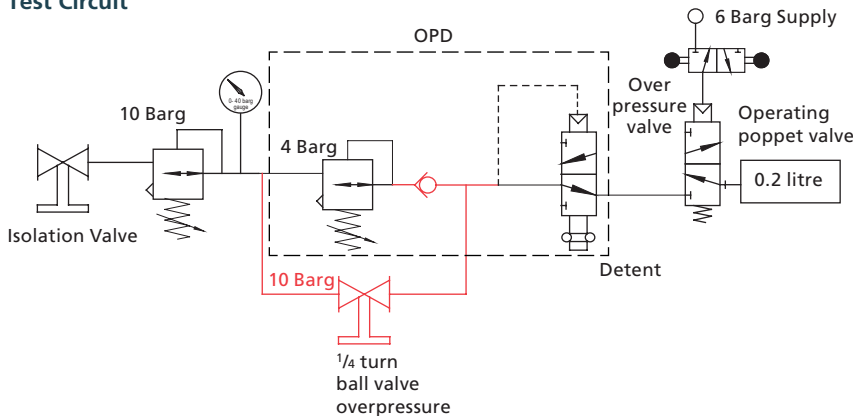

Over Pressurisation Device – OPD - Engineering Drawings

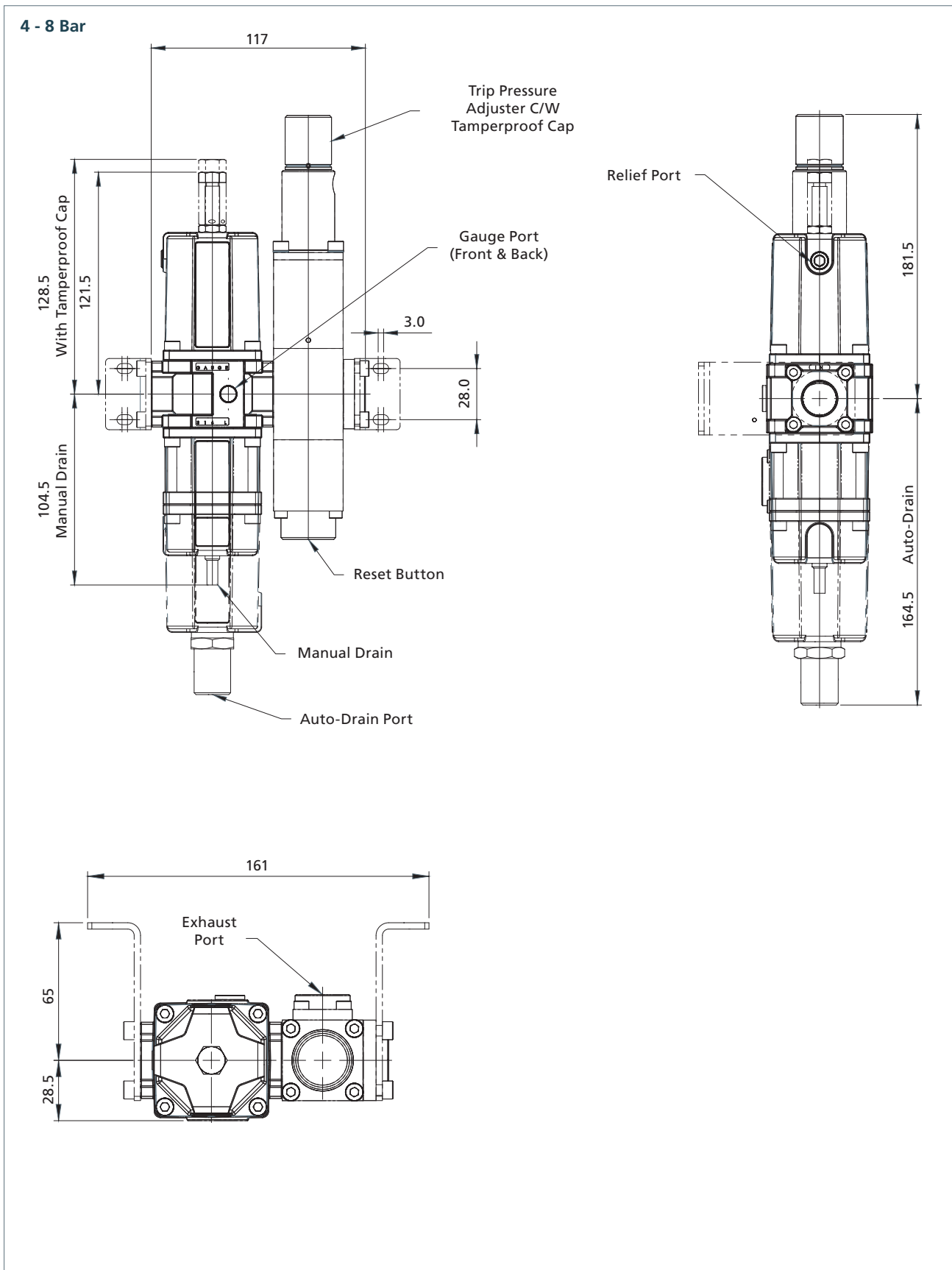

Oil & Gas industries

rotork® Midland

Since our founding in 1956, we have been known internationally as one of the oil & gas industries premier designers and manufacturers of 316L stainless steel control equipment. Over the years we have developed an enviable reputation for high quality products, reliability and innovation.

We have the ability to investigate problems and provide comprehensive solutions for the control of hydraulic and pneumatic actuated process control valves across a broad range of industries and markets. This, coupled with repeatedly delivering impressive results worldwide, sets us apart from our competitors.

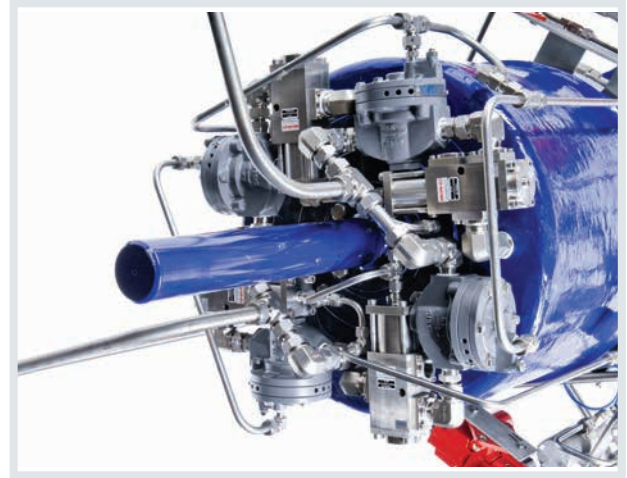

rotork® Instruments

Rotork Instruments are experts in flow control, pressure control, flow measurement and pressure measurement.

We manufacture products and components that are trusted for applications where high precision and reliability are required.

Rotork Instruments has manufacturing facilities in USA, Italy, Brazil, India, China and Singapore.

The Rotork global sales and service network supports all Rotork Instruments products. This network is the biggest global actuation support organisation in the world with direct sales offices and agents in all industrialised countries.

Customer service and field support provides quick and effective response to customer requirements.

The Rotork Site Services network is represented throughout the world and provides valuable service and assistance to all industries.



Service and Support

rotork® Site Services

Rotork staff are dedicated to providing client support across all Rotork divisions with the aim of maximising the client production cycle. These teams are based out of service centres around the world and are complemented by factory-trained agents.

Our expert technicians support Rotork customers, allowing us to deliver on our promise of global solutions backed by local service.

We provide a full range of flow control services:

- Emergency and planned service
- Actuator overhauls
- Health checks
- Preventative maintenance
- Retrofitting actuators to existing valves
- Shutdown outages
- Certified inspection and safety checks
- Factory fitting of actuators to new valves
- Plant optimisation
- Repairs and upgrades
- Loan actuator service
- System Integration projects
- Automation projects

Visit www.rotork.com to identify your nearest Rotork Site Services centre.

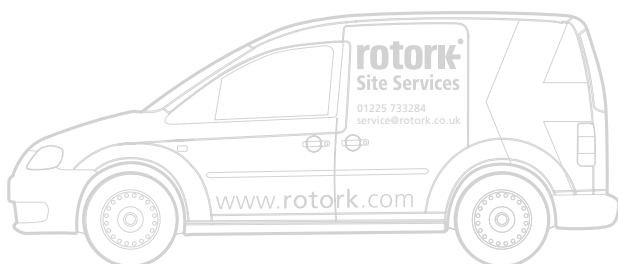

Client Support Programme

Rotork offers a premium level of product reliability and availability through the flexible Client Support Programme (CSP). Designed to facilitate the highest production demands while providing a tiered approach to maintenance, the CSP is committed to reducing maintenance downtime and costs.

Through consultation, the CSP is tuned to deliver the optimum level of maintenance through predictive maintenance algorithms.

Features of the CSP are:

- Fixed term prices for Rotork products and services
- Customisable cover based on equipment criticality to production
- Equipment performance related targets for reliability and availability
- Priority support with customisable response times
- Fully parts and labour inclusive, no additional costs or discounted labour and parts
- Fix or replace options
- Periodic equipment performance and status reports
- Built-in regular health checks on all equipment

Benefits of the CSP include but are not limited to:

- Year-on-year reduced maintenance costs
- Easy budget management
- Maximised production resulting in reduced downtime
- Year-on-year improved reliability and availability
- Optimised resource usage to accelerate in-house projects
- Reduced lifecycle costs



Service and Support

Preventative maintenance

To maximise plant up-time and minimise operating costs we offer clients a range of preventative maintenance programmes. We tailor the service in every case to reflect the type of actuators in service, the availability of asset information and the criticality of the plant.

Automation projects

This is a growing requirement and some of our service teams have the wide range of skills necessary to offer a “one-stop-shop” to automate part or all of a customer’s process. Our capabilities cover all of the installation phases (scoping, design, procurement, manufacturing, installation, commissioning) on the broad scopes that typically surround actuation projects.

Emergency and planned service

We provide a full range of actuator services, covering any type of actuator in any location, including hazardous environments. Our services include installation, commissioning and upgrading as well as connection and installation of bus communication systems. We are also skilled at troubleshooting and repairing damaged or deteriorating assets. Depending on your requirements, we can offer guaranteed emergency response times or planned response.

Shutdown outages

For those customers who run tightly-scheduled shutdowns, we engage closely in the project to help meet demanding deadlines. A typical example might involve our staff removing large numbers of actuators, overhauling them in our workshops and re-commissioning them as part of the maintenance of a larger unit.

Factory fitting of actuators to new valves

The careful assembly of valve and actuator is critical to ensure that an automated valve performs correctly and reliably. Whilst this service is often carried out by valve manufacturers, if there is a need we can provide this service.

Health checks

To help customers understand the state of their plant and assets, to better inform maintenance and replacement decisions, we offer full inspection and reporting. In addition to a detailed and intrusive inspection of the actuators, we offer extra insights from our original factory build data.

Retrofitting actuators to existing valves

We have extensive experience in fitting actuators to valves, penstocks and dampers that are already installed as part of existing plant. Whether customers are replacing obsolete actuators, changing power sources or motorising manual valves, we offer a tailor made solution to meet customers’ specific requirements.

Actuator overhauls

After a long service life it is sometimes preferable to overhaul rather than replacing actuators. In our workshops we completely strip and rebuild actuators, returning them to their original state.



rotork®

Keeping the World Flowing

www.rotork.com

A full listing of our worldwide sales and service network is available on our website.

Rotork Midland Ltd.
Patrick Gregory Road
Wolverhampton
WV11 3DZ, UK
tel +44 (0)1902 305 678
fax +44 (0)1902 305 676
email sales.midland@rotork.com

Rotork is a corporate member of the Institute of Asset Management



PUB117-001-00
Issue 06/16

As part of a process of on-going product development, Rotork reserves the right to amend and change specifications without prior notice. Published data may be subject to change. For the very latest version release, visit our website at www.rotork.com. The name Rotork is a registered trademark. Rotork recognises all registered trademarks. POWDG0616. Published and produced in the UK by Rotork Controls Limited. Registered office: Rotork plc, Brassmill Lane, Bath, BA1 3JQ, UK.