

Model T6100 Lock In Place Electro-Pneumatic I/P Transducer

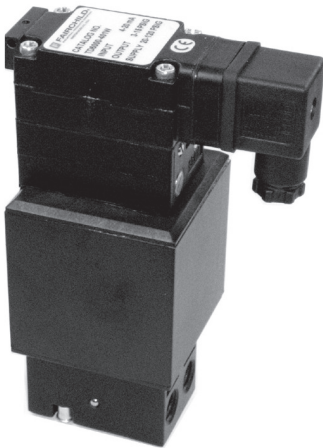

Features

- Locks in “Last Position” to accurately capture setpoint
- Extremely low drift after power loss permits transducer to maintain set point
- IP65 Rating to handle moist applications
- Single part number makes it easy to specify and cover all your needs
- Superior Construction including a moisture resistant PCB and zinc coated components
- All T6100 products are ROHS compliant

Operating Principles

Uniquely, the T6100 “Lock in Last Place” feature now provides flexibility, reliability and safety in applications requiring protection from signal failures to critical control system instruments.

Design of the T6100 relies on a proprietary integrated solenoid valve module interposed between the flapper-nozzle pilot and the booster section. Upon signal failure, an electrical charge stored within the active electronic circuit controlling the integrated solenoid valve module maintains the current to the voice coil at its last setpoint. Simultaneously, a high energy pulse closes the solenoid valve, trapping the signal pressure within the signal chamber at the last setpoint. The booster continues to provide its normal forward and exhaust flow, with the constant signal pressure now captured and maintained within the signal chamber.

The electronic circuit activates the solenoid valve immediately upon detection of a signal that falls below a base value of 3.5mA. Upon restoration of the signal, the electronic circuit sends a high energy pulse to open the solenoid valve, restoring the pilot section’s pressure control of the signal pressure to the booster as in a typical transducer. The electronic detection circuit, in series with the T6100’s signal conditioning circuit, merely adds an additional voltage drop to the T6100’s normal control loop. Advanced valve orifice design of the T6100 increases its forward flow capacity to a minimum of 5-scfm at 21-psig supply pressure.

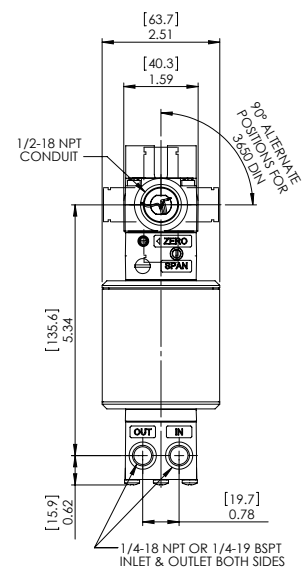
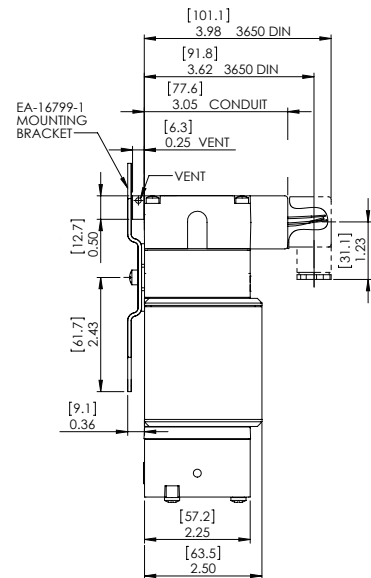
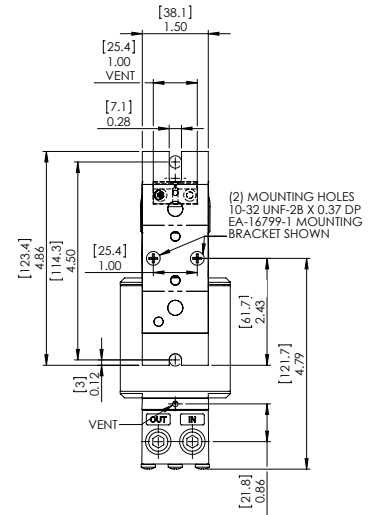

B
Model
T6100
Industrial

Model T6100 Lock In Place Electro-Pneumatic I/P Transducer

T6100 Transducer
Flow Characteristics

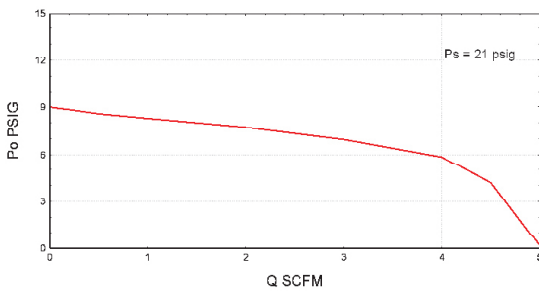

Technical Specifications:

Output Range	psig [BAR] (kPa)	3-15 [0.2-1.0] (20-100)
Supply Pressure¹	psig [BAR] (kPa)	20-40 [1.5-2.8] (150-280)
Minimum Span	psig [BAR] (kPa)	5 [0.35] (35)
Impedance	4-20 mA	197
Air Consumption (per ISA S51.1) SCFH		5.0 (.14 m ³ /HR)
Independent Linearity (per ISA S51.1)		+0.5% FS
Hysteresis & Repeatability (per ISA S51.1)		0.25% FS

Supply Pressure Effect on Output

0.25 psig, [0.17 BAR], (1.7 kPa) for a 25 psig, [1.7 BAR], (170 kPa) supply change

Flow Rate (SCFM)

5 (8.5 m³/HR) @ 21 psig, [1.7 BAR], (170 kPa) Supply & 9 psig, [0.6 BAR], (60 kPa) Output.

RFI / EMI Effect

Less than 0.5% of Span @ 30 V/m class 3 Band ABC (20-1000 mHz) per SAMA PMC 33.1 1978 and less than 0.5% of Span @ 10 V/m level 3, 27-500 mHz Band per IEC Standard 801-3 1984. EMC Directive 89/336/EEC European Norms **EN 50081-2** and **EN 50082-2**.

Temperature Range (per ISA S51.1)

-20°F to +150°F, (-28°C to +65°C)

Materials of Construction

Body and Housing Aluminum
Trim Zinc Plated Steel
Diaphragm Nitrile
Orifice Nickel Plated Brass
Weight 1000 grams
Mounting Surface Mounting, or 2" pipe mount brkts available
Mounting Position Vertical Preferred; Other positions re-zero
Degree of Protection IP 65 Rating

Failure Mode - Output Pressure locks at last value when signal fails

Drift Rate2% per hour Maximum

Electrical Connection 33mm square DIN 43650 connector
. mountable in four directions

Ordering Information

Catalog No.:

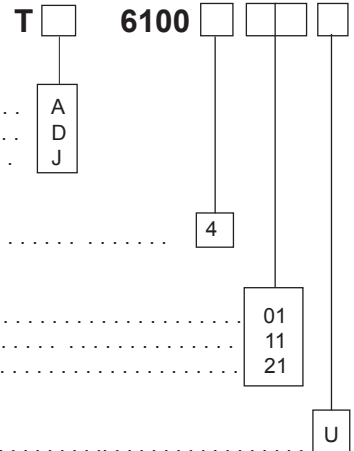

Electrical Connection

1/2" NPT Conduit Fitting A
DIN 43650 Connection D
Junction Box J

Input

4-20 mA 4
(two wire, 7 Volt drop maximum at 20 mA)

Output*

3-15 psig 01
0.2-1.0 BAR 11
20-100 kPa 21

Options:

BSPT Thread** U

* Special Ranges Available Upon Request

** Standard Pneumatic Connections are 1/4" NPT

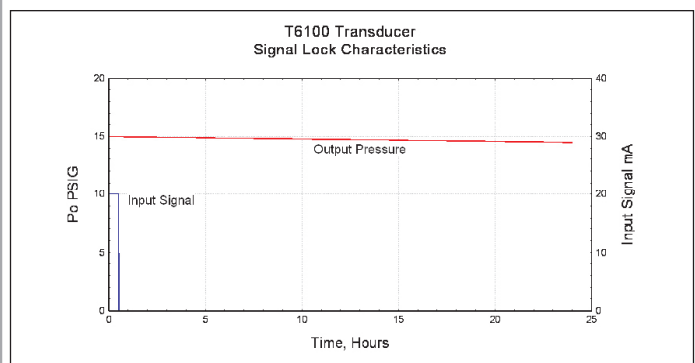
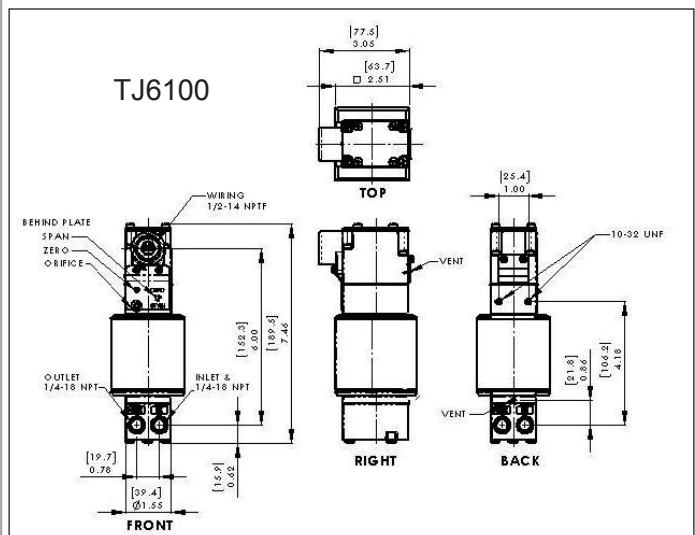

Installation

For installation instructions, refer to the *Fairchild Model T6100 Lock In Place Electro-Pneumatic I/P, Transducer Installation, Operation and Maintenance Instructions*, IS-10006100.